

# PROGETTAZIONE DI UNA CONCEPT CAR CON SISTEMA MODULARE MUV (MODULAR UTILITY VEHICLE)

Laurea in Disegno Industriale e Ambientale

a.a. 2015/2016

Sessione estiva 25 Luglio 2016

Laureando: Pasquale Parisi

Relatore: Arch. Andrea Lupacchini

Correlatore: Ing. Pierluigi Antonini



Scuola di Ateneo  
Architettura e Design  
Eduardo Vittoria



<<...L'automobile è un espressione di libertà, e il rischio che stiamo correndo è quello di ammazzarci perché ce n'è troppa...>>

Enzo Ferrari

## LA STRUTTURA DEL MERCATO ITALIANO DELL' AUTOMOBILE IMMATRICOLAZIONI

Per segmento	aprile		Var. % aprile 2016/2015	gennaio/aprile		Var. % gennaio/aprile 2016/2015
	2016	2015		2016	2015	
A - Piccole	29.013	27.621	5,0	125.627	104.697	20,0
B - Utilitarie	69.837	63.903	9,3	280.888	247.344	13,6
C - Medie	47.670	39.018	22,2	194.612	153.724	26,6
D - Medie superiori	18.507	16.649	11,2	78.535	65.634	19,7
E - Superiori	3.199	2.521	26,9	12.255	10.273	19,3
F - Alto di gamma	470	446	5,4	1.913	1.658	15,4
<b>totale</b>	<b>168.696</b>	<b>150.158</b>	<b>12,3</b>	<b>693.830</b>	<b>583.330</b>	<b>18,9</b>

Per carrozzeria	aprile		Var. % aprile 2016/2015	gennaio/aprile		Var. % gennaio/aprile 2016/2015
	2016	2015		2016	2015	
Berline	94.622	83.937	12,7	383.622	321.724	19,2
Crossover	30.066	24.340	23,5	124.951	93.349	33,9
Fuoristrada	13.211	11.206	17,9	54.115	43.758	23,7
Station Wagon	12.290	10.885	12,9	50.909	43.595	16,8
Monovolume Piccolo	7.311	8.228	-11,1	32.990	37.468	-12,0
Monovolume Compatto	6.059	6.631	-8,6	27.044	26.020	3,9
Multispazio	1.878	2.185	-14,1	8.467	7.674	10,3
Coupè	1.279	1.459	-12,3	4.924	5.444	-9,6
Monovolume Grande	901	445	102,5	3.756	1.604	134,2
Cabrio e Spider	1.079	842	28,1	3.052	2.694	13,3
<b>totale</b>	<b>168.696</b>	<b>150.158</b>	<b>12,3</b>	<b>693.830</b>	<b>583.330</b>	<b>18,9</b>

# IMMATRICOLAZIONI IN ITALIA DI AUTOVETTURE

## TOP TEN PER CARROZZERIA

FUORISTRADA SUV									
n.	MARCA	MODELLO	aprile		n.	MARCA	MODELLO	gennaio / aprile	
			2016	2015				2016	2015
1	JEEP	RENEGADE	1.378	923	1	JEEP	RENEGADE	5.590	3.416
2	LAND ROVER	RANGE EVOQUE	822	603	2	LAND ROVER	RANGE EVOQUE	3.862	3.368
3	AUDI	Q3	732	645	3	LAND ROVER	DISCOVERY SPORT	2.894	1.078
4	LAND ROVER	DISCOVERY SPORT	669	466	4	AUDI	Q3	2.649	2.207
5	MERCEDES	GLC	618	--	5	MERCEDES	GLC	2.327	--
6	FORD	KUGA	557	337	6	SUZUKI	VITARA	1.960	400
7	SUZUKI	VITARA	487	256	7	DACIA	DUSTER	1.876	1.503
8	HYUNDAI	TUCSON	472	--	8	FORD	KUGA	1.823	1.536
9	FIAT	500X	344	422	9	FIAT	500X	1.755	1.582
10	VOLKSWAGEN	TIGUAN	342	395	10	BMW	X1	1.477	572
altre			6.790	7.159	altre			27.902	28.096
<b>totale fuoristrada</b>			<b>13.211</b>	<b>11.206</b>				<b>54.115</b>	<b>43.758</b>
<b>% fuoristrada su tot. mercato</b>			<b>7,8</b>	<b>7,5</b>				<b>7,8</b>	<b>7,5</b>

CROSSOVER									
n.	MARCA	MODELLO	aprile		n.	MARCA	MODELLO	gennaio / aprile	
			2016	2015				2016	2015
1	FIAT	500X	3.783	2.842	1	FIAT	500X	17.206	6.863
2	NISSAN	QASHQAI	2.574	2.596	2	RENAULT	CAPTUR	10.383	8.982
3	RENAULT	CAPTUR	2.519	2.494	3	NISSAN	QASHQAI	10.030	10.154
4	PEUGEOT	2008	2.315	2.054	4	PEUGEOT	2008	8.743	7.260
5	OPEL	MOKKA	2.309	1.903	5	OPEL	MOKKA	8.253	8.313
6	DACIA	DUSTER	1.839	1.514	6	JEEP	RENEGADE	6.848	4.865
7	FORD	ECOSPORT	1.775	657	7	HYUNDAI	TUCSON	6.684	--
8	HYUNDAI	TUCSON	1.603	--	8	DACIA	DUSTER	6.640	6.645
9	JEEP	RENEGADE	1.518	1.315	9	FORD	ECOSPORT	6.549	3.939
10	KIA	SPORTAGE	1.264	1.463	10	KIA	SPORTAGE	6.130	5.883
altre			8.567	7.502	altre			37.485	30.445
<b>totale crossover</b>			<b>30.066</b>	<b>24.340</b>				<b>124.951</b>	<b>93.349</b>
<b>% crossover su tot. mercato</b>			<b>17,8</b>	<b>16,2</b>				<b>18,0</b>	<b>16,0</b>

BERLINE									
n.	MARCA	MODELLO	aprile		n.	MARCA	MODELLO	gennaio / aprile	
			2016	2015				2016	2015
1	FIAT	PANDA	14.000	11.914	1	FIAT	PANDA	58.196	44.903
2	LANCIA	YPSILON	6.923	5.451	2	LANCIA	YPSILON	26.385	20.943
3	FIAT	PUNTO	6.288	5.663	3	FIAT	500	19.474	17.401
4	VOLKSWAGEN	POLO	4.416	3.485	4	FIAT	PUNTO	17.188	20.429
5	RENAULT	CLIO	3.974	4.247	5	FORD	FIESTA	16.618	14.700
6	VOLKSWAGEN	GOLF	3.742	3.332	6	VOLKSWAGEN	POLO	16.450	13.038
7	FORD	FIESTA	3.604	3.767	7	RENAULT	CLIO	15.393	14.830
8	FIAT	500	3.348	4.510	8	VOLKSWAGEN	GOLF	15.277	12.280
9	PEUGEOT	208	3.320	2.542	9	TOYOTA	YARIS	13.404	11.463
10	TOYOTA	YARIS	3.280	2.812	10	PEUGEOT	208	13.138	10.180
altre			41.727	36.214	altre			172.099	141.557
<b>totale berline</b>			<b>94.622</b>	<b>83.937</b>				<b>383.622</b>	<b>321.724</b>
<b>% berline su tot. mercato</b>			<b>56,1</b>	<b>55,9</b>				<b>55,3</b>	<b>55,2</b>

MONOVOLUME PICCOLO									
n.	MARCA	MODELLO	aprile		n.	MARCA	MODELLO	gennaio / aprile	
			2016	2015				2016	2015
1	FIAT	500L	4.149	4.821	1	FIAT	500L	19.388	22.819
2	FORD	B-MAX	900	838	2	CITROEN	C3	3.560	3.446
3	HYUNDAI	IX20	685	426	3	FORD	B-MAX	3.558	3.275
4	CITROEN	C3	613	922	4	OPEL	MERIVA	2.475	3.030
5	OPEL	MERIVA	577	680	5	HYUNDAI	IX20	2.410	2.284
6	KIA	VENGA	381	345	6	KIA	VENGA	1.574	1.296
7	NISSAN	NOTE	6	--	7	NISSAN	NOTE	20	4
8	OPEL	AGILA	--	102	8	LANCIA	MUSA	3	1
9	FORD	FUSION	--	1	9	OPEL	AGILA	1	817
10	FIAT	IDEA	--	--	10	FIAT	IDEA	1	1
altre			--	93	altre			--	495
<b>totale monovolume piccolo</b>			<b>7.311</b>	<b>8.228</b>				<b>32.990</b>	<b>37.468</b>
<b>% mon. piccolo su tot. mercato</b>			<b>4,3</b>	<b>5,5</b>				<b>4,8</b>	<b>6,4</b>

MONOVOLUME COMPATTO									
n.	MARCA	MODELLO	aprile		n.	MARCA	MODELLO	gennaio / aprile	
			2016	2015				2016	2015
1	FORD	C-MAX	1.388	1.239	1	FORD	C-MAX	6.269	5.594
2	BMW	SERIE 2	1.120	700	2	BMW	SERIE 2	4.092	3.017
3	MERCEDES	CLASSE B	782	696	3	CITROEN	C4	3.340	2.995
4	CITROEN	C4	651	740	4	MERCEDES	CLASSE B	3.053	3.028
5	VOLKSWAGEN	TOURAN	440	310	5	VOLKSWAGEN	TOURAN	2.283	1.196
6	VOLKSWAGEN	GOLF	339	575	6	VOLKSWAGEN	GOLF	1.672	2.010
7	OPEL	ZAFIRA	328	308	7	RENAULT	SCENIC	1.575	2.975
8	RENAULT	SCENIC	276	935	8	TOYOTA	VERSO	1.292	1.169
9	KIA	CARENS	243	239	9	OPEL	ZAFIRA	1.042	1.260
10	DACIA	LODGY	174	184	10	KIA	CARENS	848	830
altre			318	705	altre			1.578	1.946
<b>totale monovolume compatto</b>			<b>6.059</b>	<b>6.631</b>				<b>27.044</b>	<b>26.020</b>
<b>% mon. compatto su tot. mercato</b>			<b>3,6</b>	<b>4,4</b>				<b>3,9</b>	<b>4,5</b>

MULTISPAZIO									
n.	MARCA	MODELLO	aprile		n.	MARCA	MODELLO	gennaio / aprile	
			2016	2015				2016	2015
1	FIAT	QUBO	494	697	1	FIAT	QUBO	2.674	2.667
2	FIAT	DOBLO	256	270	2	FIAT	DOBLO	1.089	1.069
3	DACIA	DOKKER	232	252	3	DACIA	DOKKER	894	689
4	RENAULT	KANGOO	183	125	4	RENAULT	KANGOO	829	474
5	CITROEN	BERLINGO	167	249	5	CITROEN	BERLINGO	721	630
6	VOLKSWAGEN	CADDY	156	91	6	VOLKSWAGEN	CADDY	575	459
7	FORD	TOURNEO COURIER	134	138	7	PEUGEOT	PARTNER	554	661
8	PEUGEOT	PARTNER	126	172	8	FORD	TOURNEO COURIER	543	394
9	FORD	TOURNEO	79	78	9	FORD	TOURNEO	357	244
10	PEUGEOT	BIPPER	37	71	10	PEUGEOT	BIPPER	160	253
altre			14	42	altre			71	134
<b>totale multispazio</b>			<b>1.878</b>	<b>2.185</b>				<b>8.467</b>	<b>7.674</b>
<b>% multispazio su tot. mercato</b>			<b>1,1</b>	<b>1,5</b>				<b>1,2</b>	<b>1,3</b>



SEGMENTO A



SEGMENTO B



SEGMENTO C



SEGMENTO B



SEGMENTO C



SEGMENTO B

# TIPOLOGIA CARROZZERIA DI MAGGIORE INTERESSE CON RELATIVO TARGET DI CLIENTELA A CUIE ORIENTATA

## CITY CAR



MODELLO	SEGMENTO	DIMENSIONI cm Lunghezza/Larghezza/Altezza	TARGET	PREZZO
FIAT PANDA	A	L: 365/ L:164/ H:155	SINGLE, FAMIGLIA CON UN FIGLIO	13,300,00 €
PEUGEOT 108	A	L: 348/ L:162/ H:146	SINGLE, FAMIGLIA CON UN FIGLIO	10,500,00 €
VOLKSWAGEN UP	A	L: 354/ L:164/ H:149	SINGLE, FAMIGLIA CON UN FIGLIO	11,150,00 €

Lunghezza 3,40m <> 3,70m /Larghezza 1,60m <> 1,64m /Altezza 1,46m <> 1,55m - Prezzo € 10,000,00 <>13,500,00

## COMPATTE



MODELLO	SEGMENTO	DIMENSIONI cm Lunghezza/Larghezza/Altezza	TARGET	PREZZO
FIAT PUNTO	B	L: 407/ L:169/ H:149	SINGLE, FAMIGLIA CON UN FIGLIO	14,100,00 €
MINI 5 PORTE	B	L: 398/ L:173/ H:143	SINGLE, FAMIGLIA CON UN FIGLIO	17,750,00 €
TOYOTA YARIS	B	L: 395/ L:170/ H:151	SINGLE, FAMIGLIA CON UN FIGLIO	11,250,00 €

Lunghezza 3,90m <> 4,10m /Larghezza 1,65m <> 1,75m /Altezza 1,43m <> 1,51m - Prezzo € 11,000,00 <>18,00,00

# TIPOLOGIA CARROZZERIA DI MAGGIORE INTERESSE CON RELATIVO TARGET DI CLIENTELA A CUI E ORIENTATA

## MONOVOLUME PICCOLO



MODELLO	SEGMENTO	DIMENSIONI cm Lunghezza/Larghezza/Altezza	TARGET	PREZZO
FIAT 500L	B	L: 415/ L:178/ H:167	FAMIGLIA CON DUE FIGLI	16,400,00 €
NISSAN NOTE	B	L: 410/ L:170/ H:153	FAMIGLIA CON DUE FIGLI	13,800,00 €
FORD B-MAX	B	L: 408/ L:175/ H:160	FAMIGLIA CON DUE FIGLI	17,750,00 €

Lunghezza 4,08m <> 4,20m /Larghezza 1,70m <> 1,78m /Altezza 1,53m <> 1,67m - Prezzo € 14,000,00 <>18,000,00

## MONOVOLUME COMPATTO



MODELLO	SEGMENTO	DIMENSIONI cm Lunghezza/Larghezza/Altezza	TARGET	PREZZO
FORD C-MAX	C	L: 438/ L:183/ H:161	FAMIGLIE CON PIU DI DUE FIGLI	20,250,00 €
BMW SERIE 2 ACTIVE TOURER	C	L: 434/ L:180/ H:156	FAMIGLIE CON PIU DI DUE FIGLI	25,300,00 €
MERCEDES CLASSE B	C	L: 439/ L:179/ H:156	FAMIGLIE CON PIU DI DUE FIGLI	23,560,00 €

Lunghezza 4,30m <> 4,40m /Larghezza 1,79m <> 1,83m /Altezza 1,56m <> 1,61m - Prezzo € 20,000,00 <>25,500,00

# TIPOLOGIA CARROZZERIA DI MAGGIORE INTERESSE CON RELATIVO TARGET DI CLIENTELA A CUI E ORIENTATA

## CROSSOVER



MODELLO	SEGMENTO	DIMENSIONI cm Lunghezza/Larghezza/Altezza	TARGET	PREZZO
FIAT 500X	B	L: 425/ L:180/ H:160	SIGLE/COPPIA E FAMIGLIA	17,850,00 €
RENAULT CAPTURE	B	L: 412/ L:178/ H:157	SIGLE/COPPIA E FAMIGLIA	16,850,00 €
OPEL MOKKA	B	L: 428/ L:178/ H:166	SIGLE/COPPIA E FAMIGLIA	22,800,00 €

Lunghezza 4,10m <> 4,30m /Larghezza 1,78m <> 1,80m /Altezza 1,57m <> 1,66m - Prezzo € 16,500,00 <>23,000,00

## SUV



MODELLO	SEGMENTO	DIMENSIONI cm Lunghezza/Larghezza/Altezza	TARGET	PREZZO
JEEP RENEGADE	C	L: 423/ L:180/ H:169	COPPIA E FAMIGLIA	24,300,00 €
FORD KUGA	C	L: 452/ L:184/ H:170	COPPIA E FAMIGLIA	24,750,00 €
HUNDAY TUCSON	C	L: 448/ L:185/ H:165	COPPIA E FAMIGLIA	21,800,00 €

Lunghezza 4,20m <> 4,52m /Larghezza 1,80m <> 1,85m /Altezza 1,65m <> 1,70m - Prezzo € 21,000,00 <>25,000,00

# TIPOLOGIA CARROZZERIA DI MAGGIORE INTERESSE CON RELATIVO TARGET DI CLIENTELA A CUI È ORIENTATA

## MULTISPAZIO



MODELLO	SEGMENTO	DIMENSIONI cm Lunghezza/Larghezza/Altezza	TARGET	PREZZO
FIAT DOBLÒ	B	L: 441/ L:183/ H:185	LAVORATORE AUTONOMO, FAMIGLIA	18,550,00 €
RENAULT KANGOO	B	L: 428/ L:183/ H:187	LAVORATORE AUTONOMO, FAMIGLIA	19,550,00 €
FORD TOURNEO	B	L: 442/ L:183/ H:185	LAVORATORE AUTONOMO, FAMIGLIA	19,750,00 €

Lunghezza 4,28m <> 4,42m /Larghezza 1,80m <> 1,83m /Altezza 1,85m <> 1,87m - Prezzo € 18,500,00 <>20,000,00



# COME OTTENERE UN'AUTOVETTURA CHE ABBAIA LE STESS E CARATTERISTICHE TECNICHE E STILISTICHE DEI SEGMENTI APPENA EVIDENZIATI?

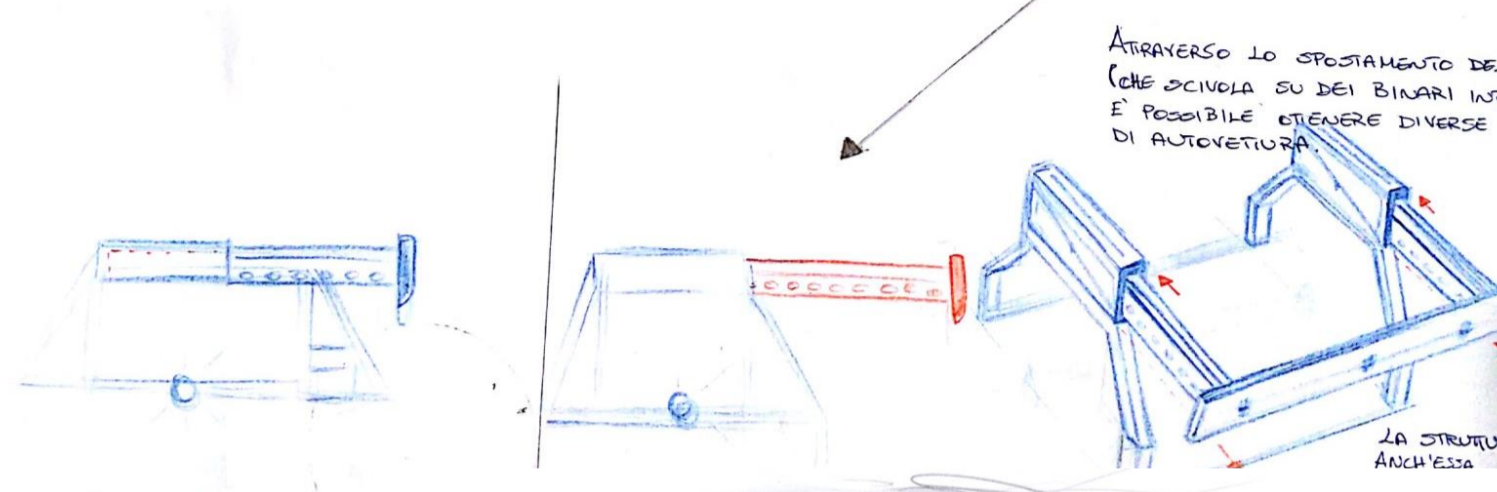
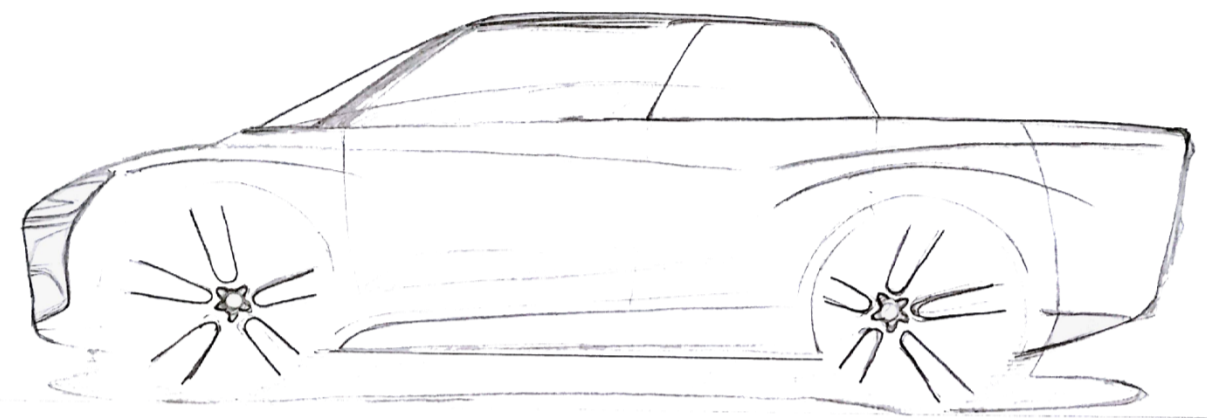
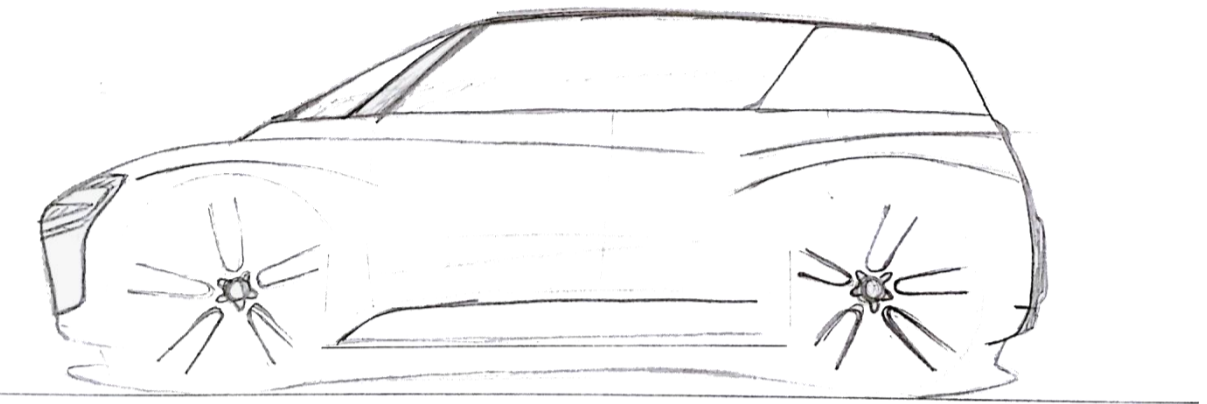
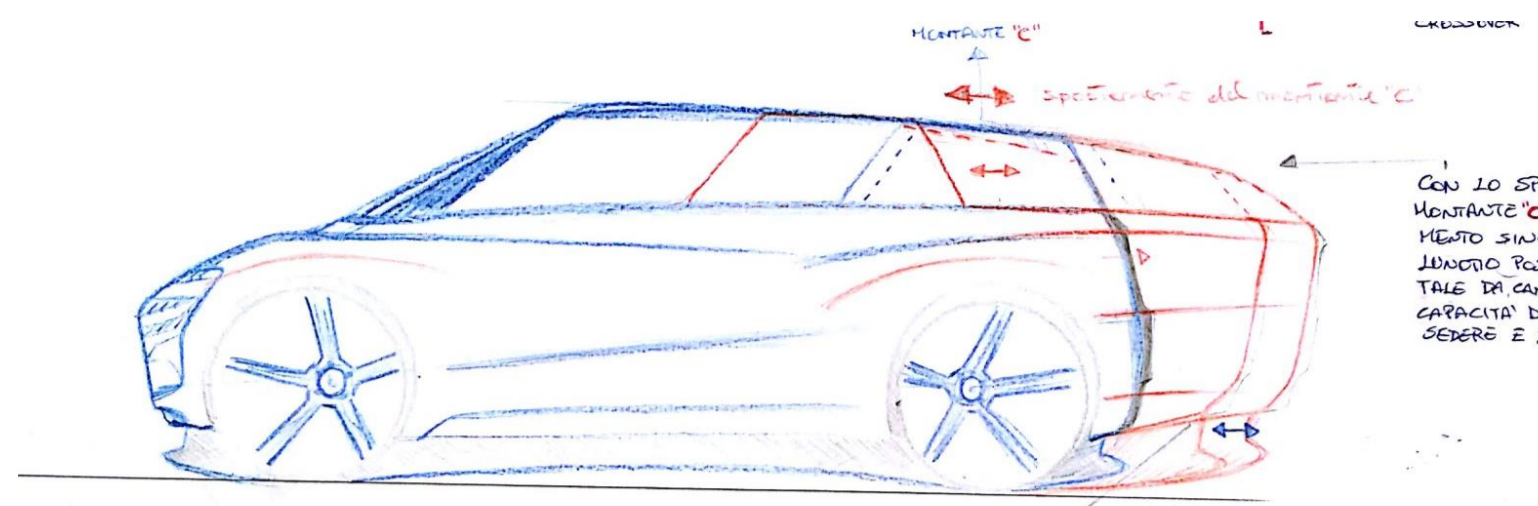
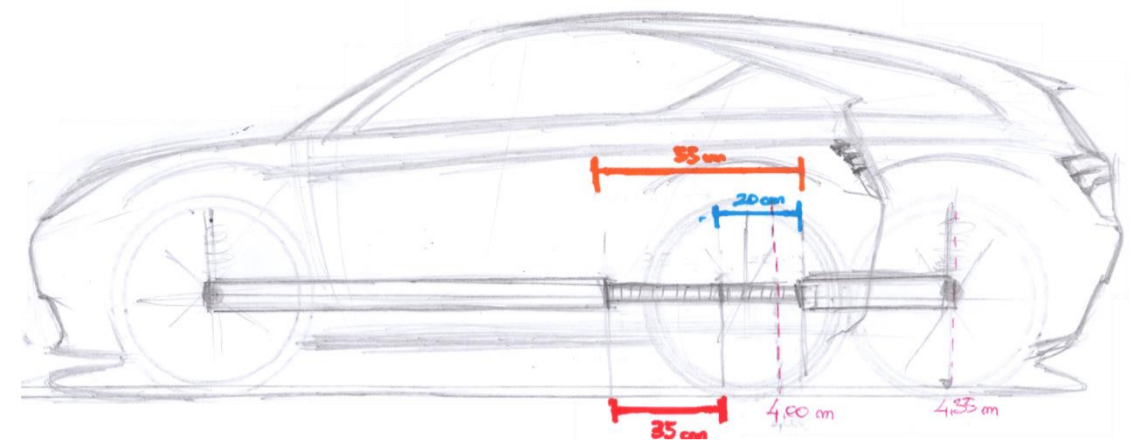
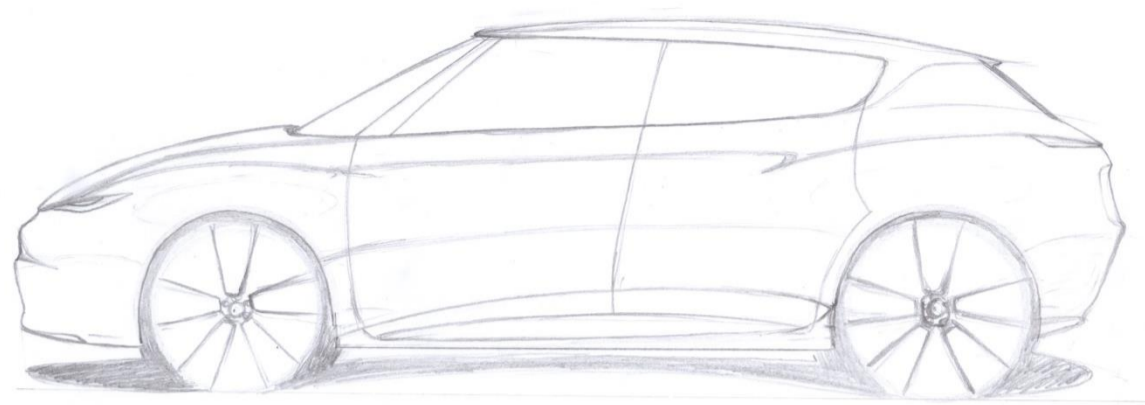

“L’obiettivo prefissato per questa innovation car è creare una tipologia di autovettura avente un telaio dinamico-adattivo in grado di ottenere, in base alle esigenze, diverse tipologie di autovetture con lunghezza e capacità di carico differenti, in pratica un’autovettura che si adatta agli eventi e racchiude in essa molteplici conformazioni.”

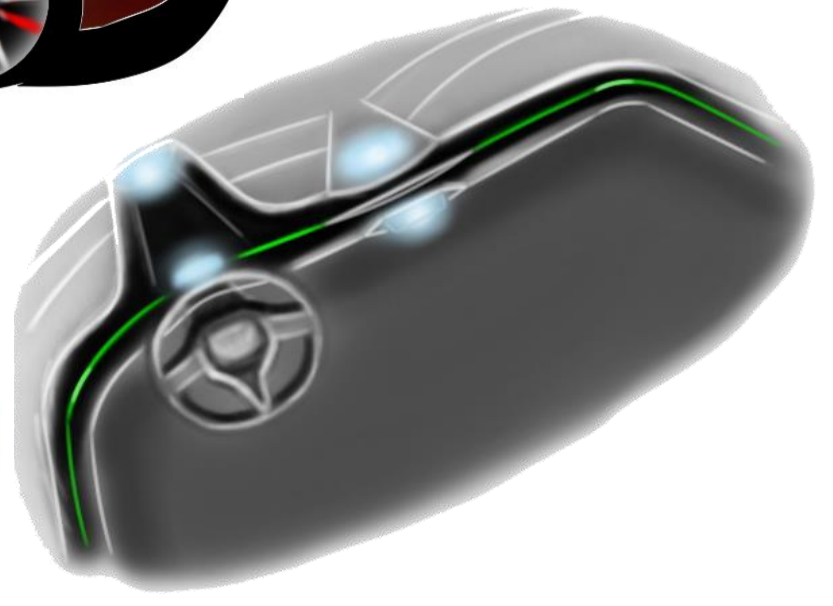
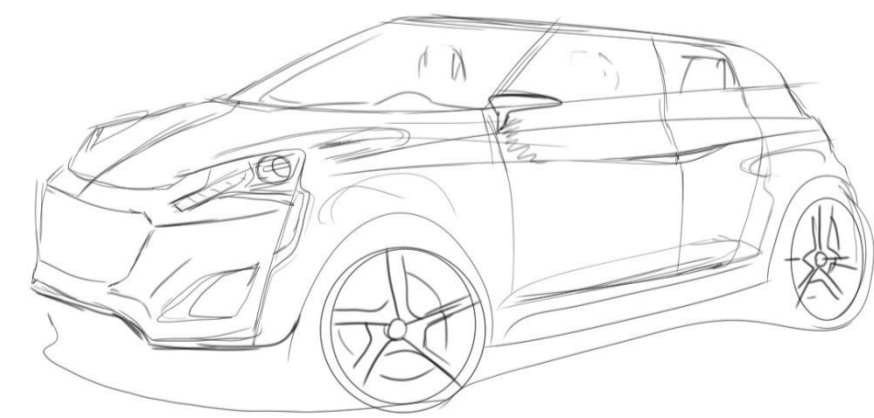
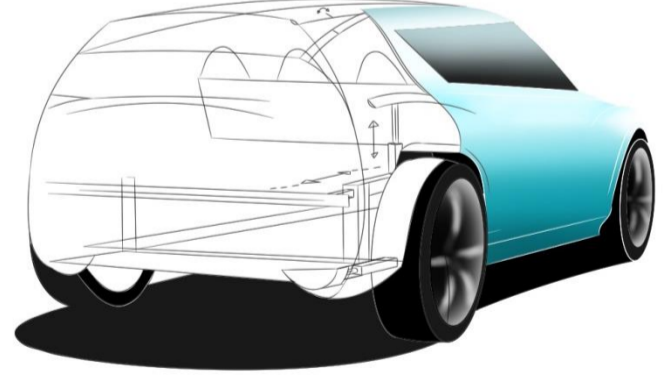
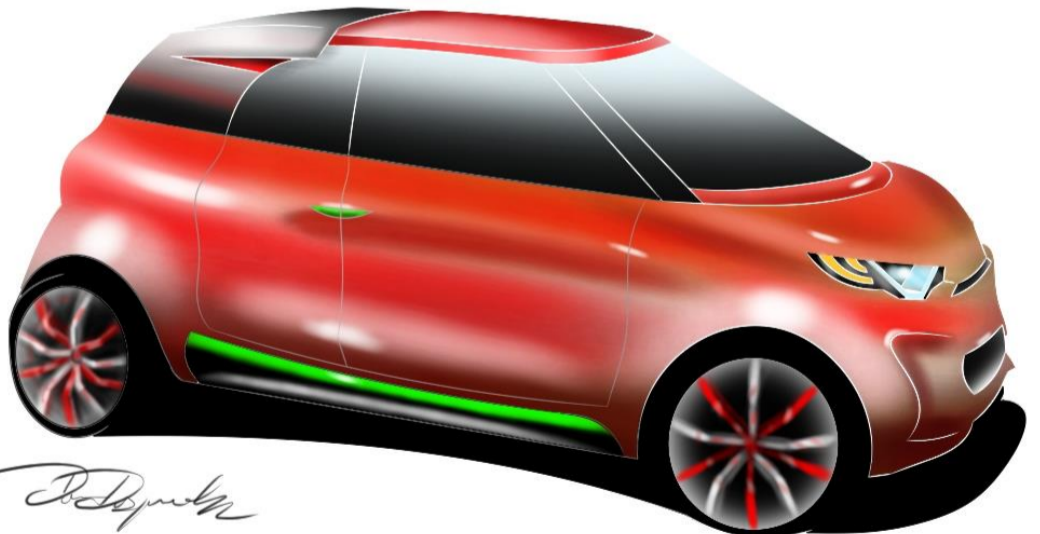
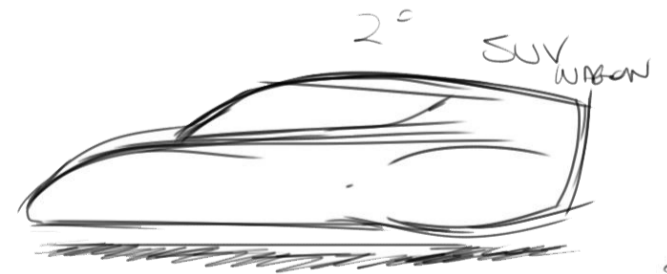
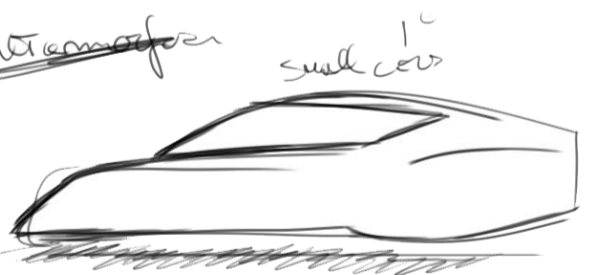
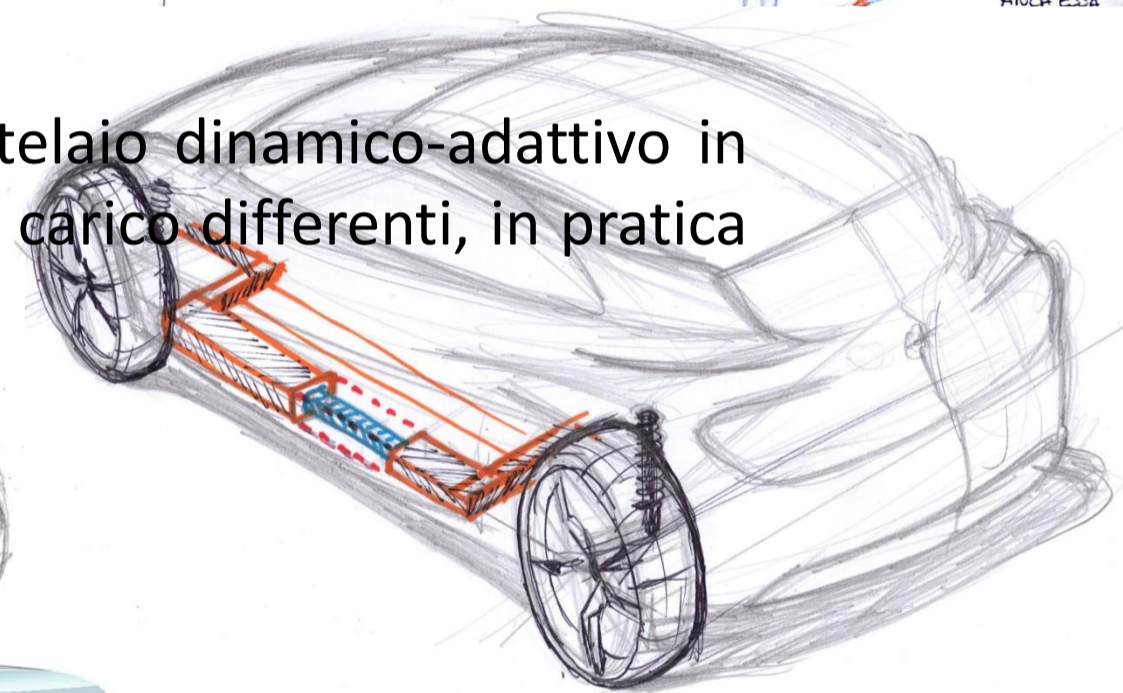
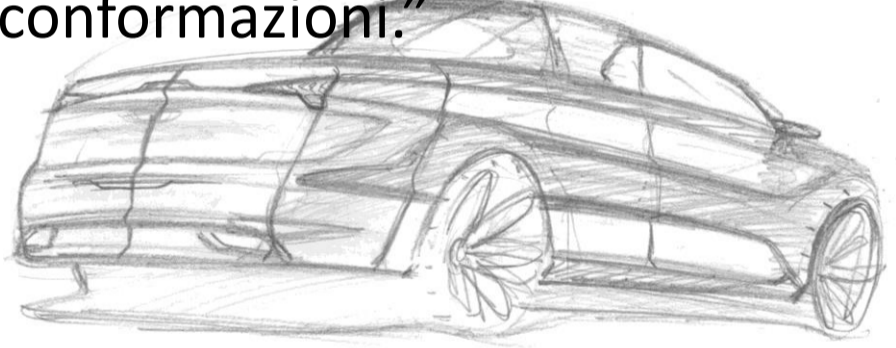
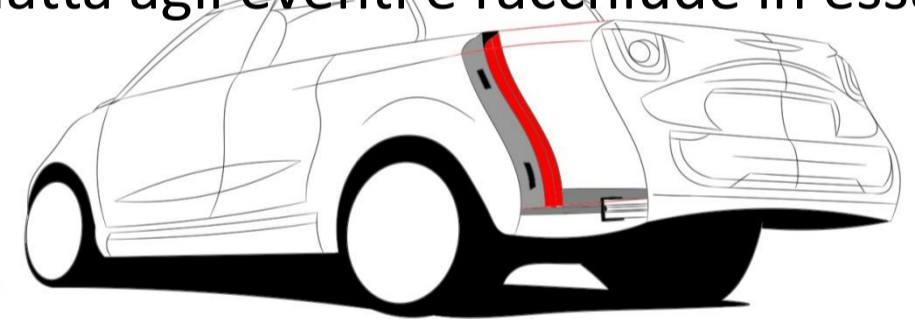

**MUV**  
MODULAR UTILITY VEHICLE

**MUV**



MUV CITY



MUV COMPACT



MUV CROSSOVER

**MODULAR**

**UTILITY**

**VEHICLE**



MUV PICK UP SMALL



MUV PICK UP MEDIUM



MUV PICK UP LONG

MUV  
DESIGN



MUV E-POWER



MUV  
CONFIGURAZIONI

MUV CITY  
LIBERTÀ DI MOVIMENTO



1810mm



1615mm



3787mm

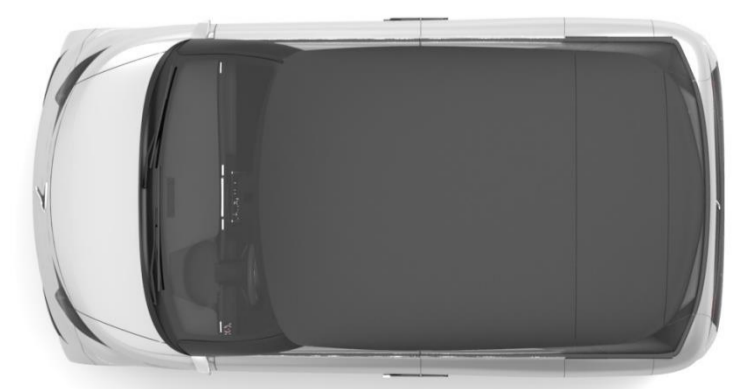

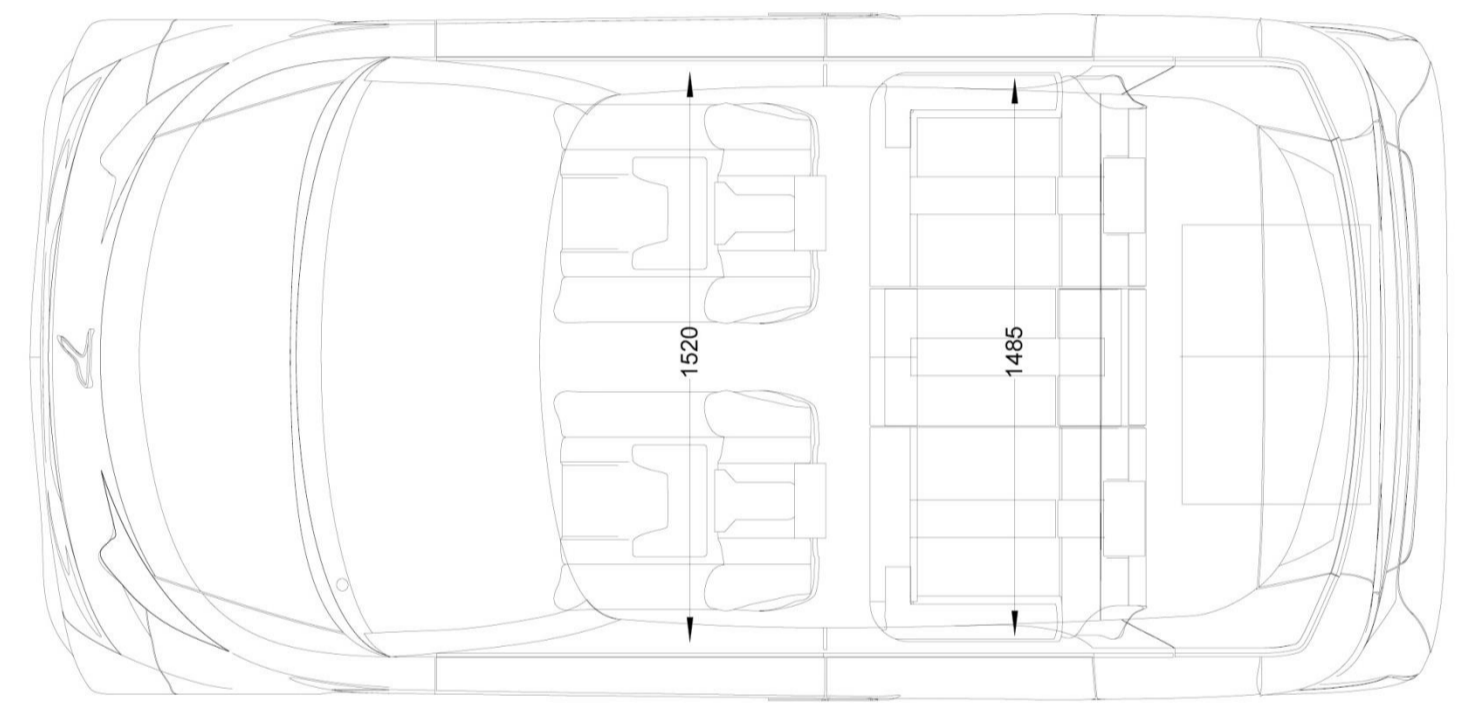
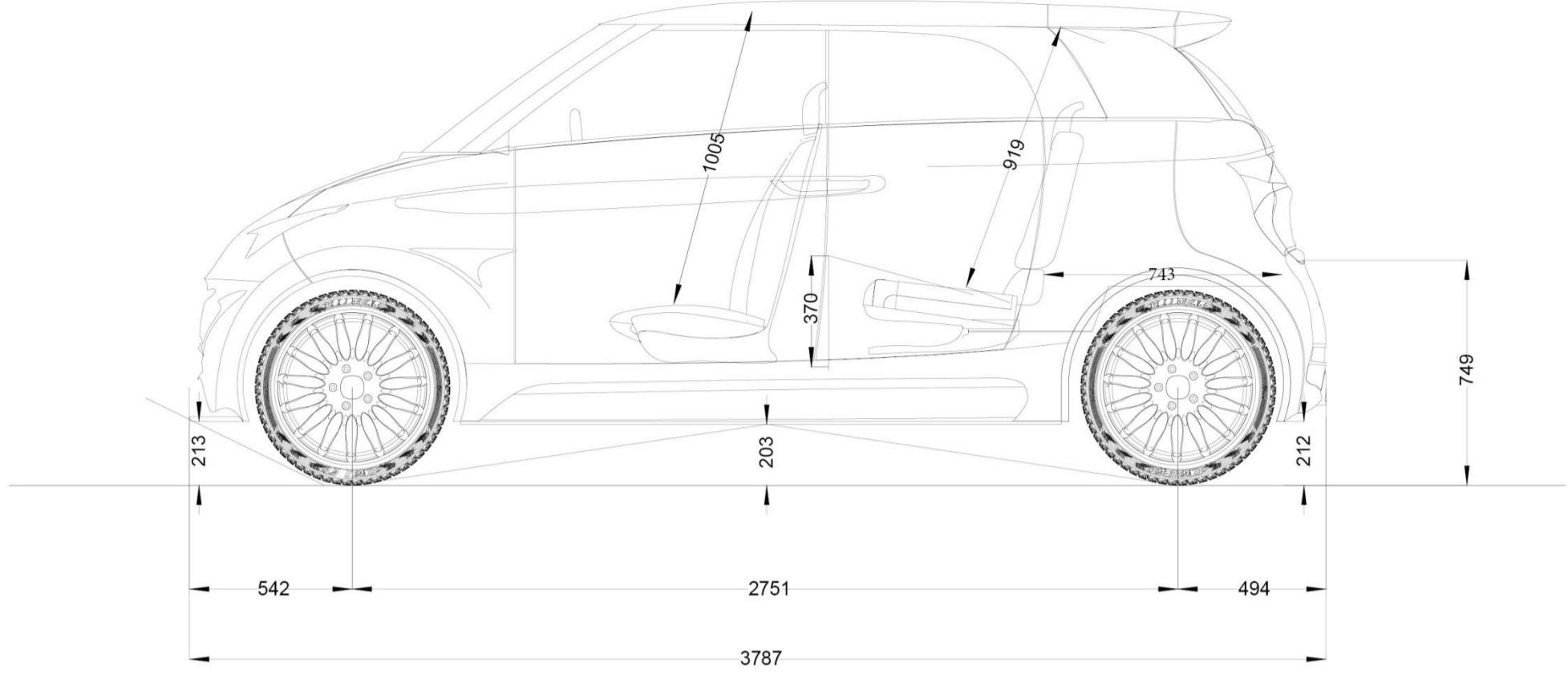

1. VANO BAGAGLI ANTERIORE



CONFIGURAZIONE SEDILI

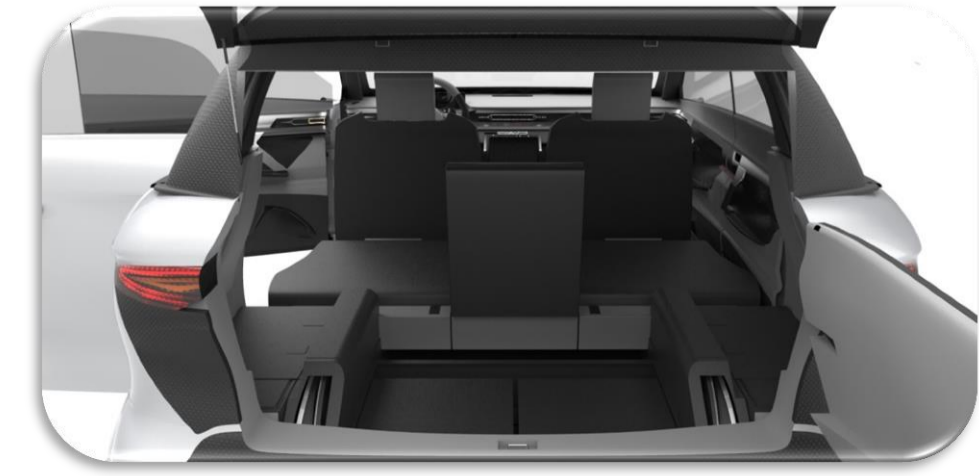
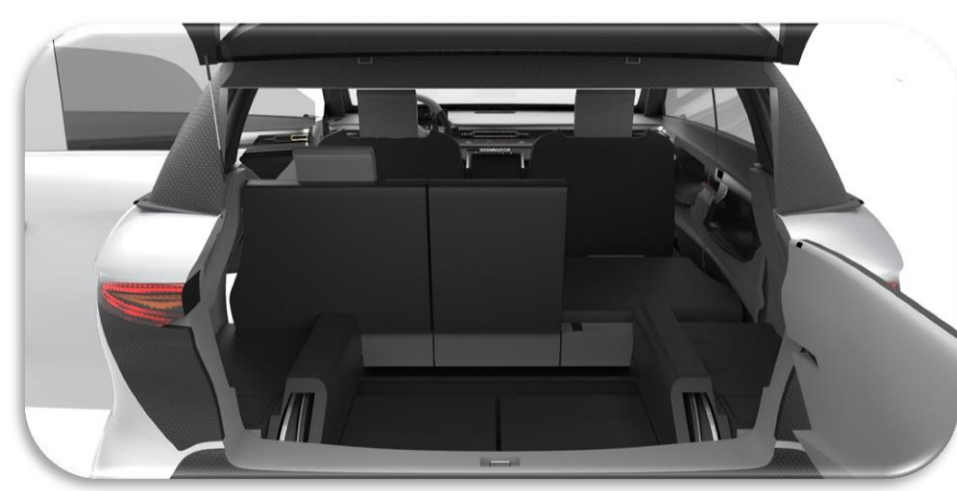



MUV  
CONFIGURAZIONI

MUV COMPACT  
FORME UNICHE



1810mm



1615mm

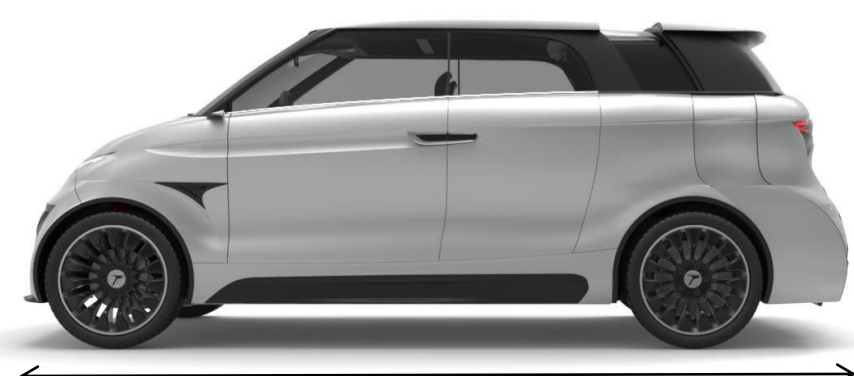

4086mm

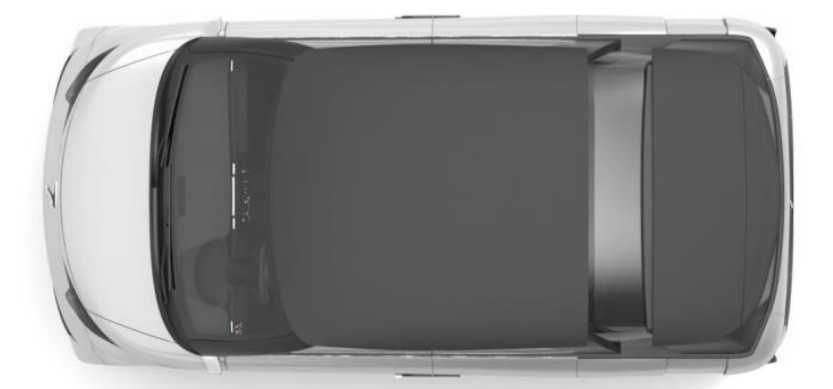

# MUV

## ACCESSIBILITÀ COMPACT

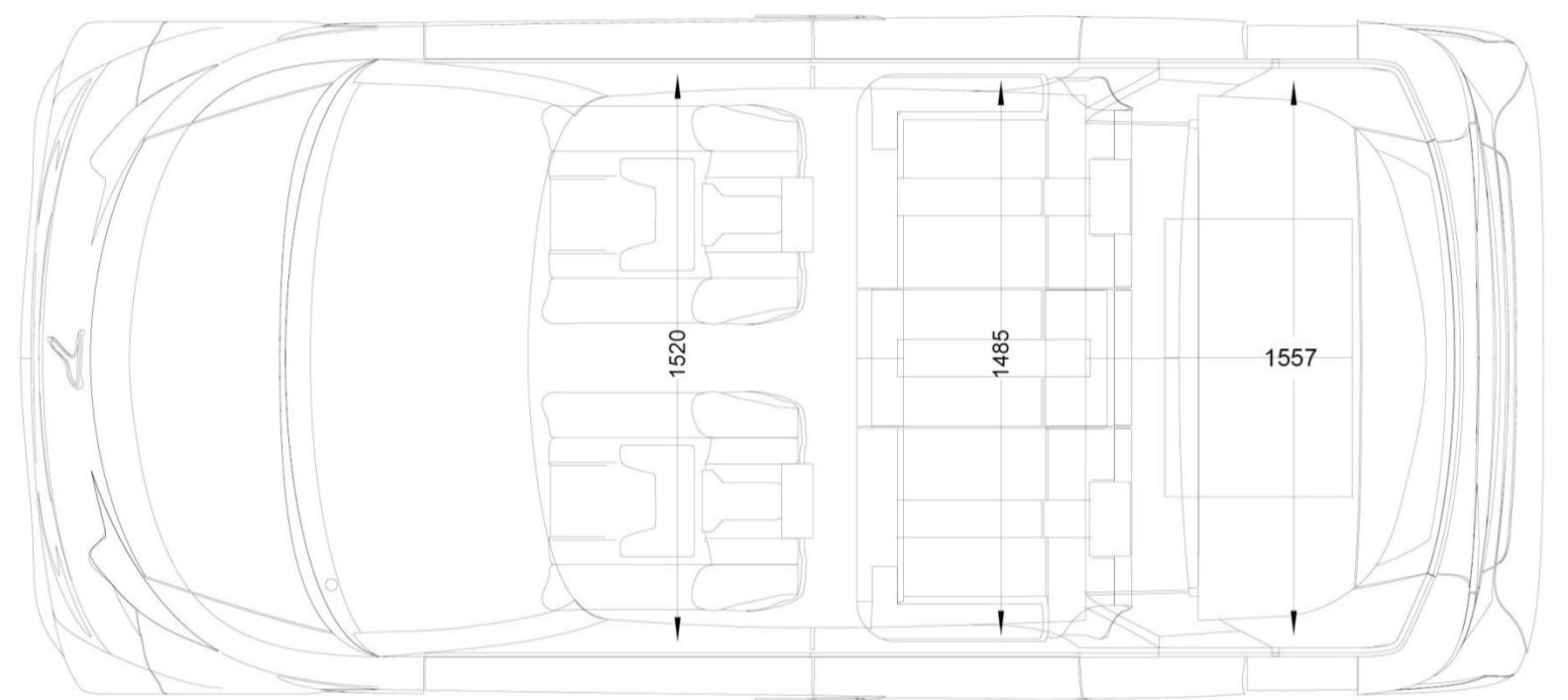
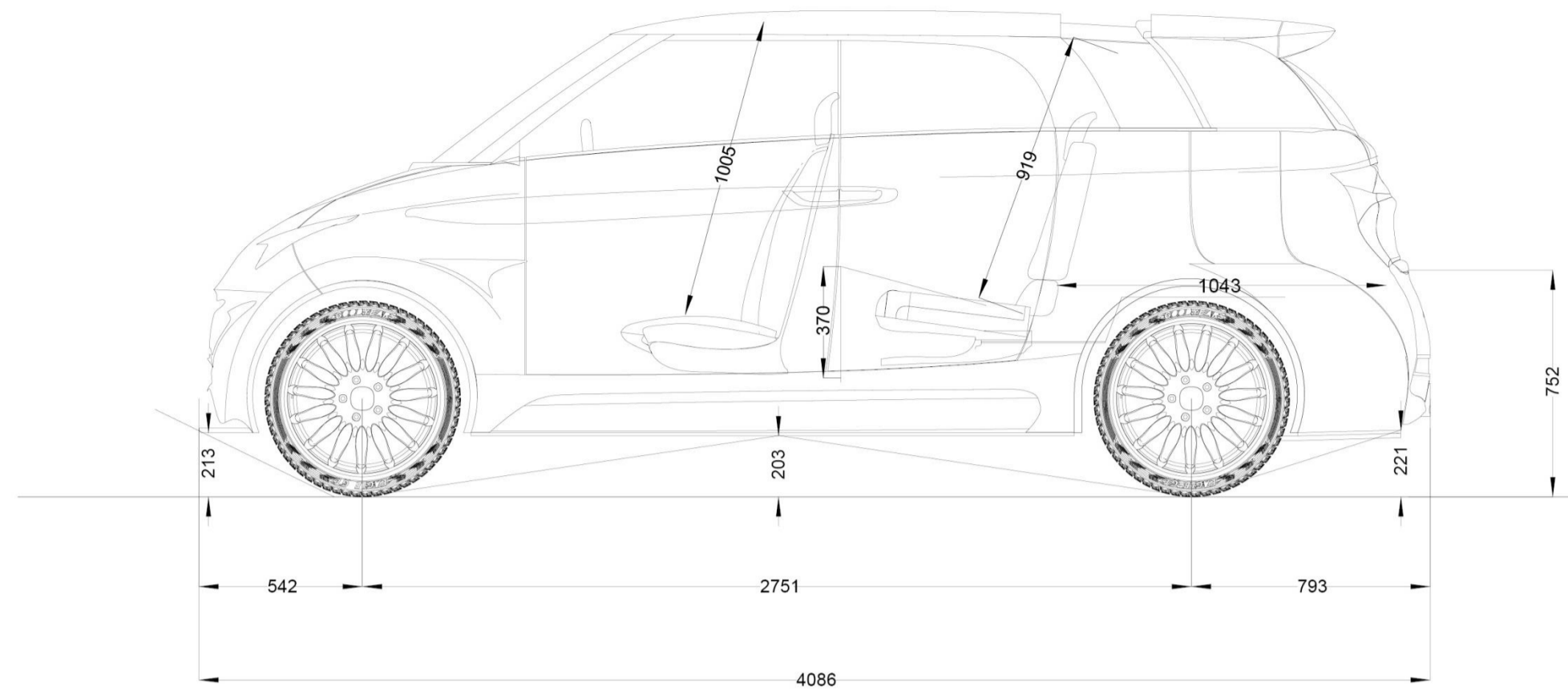

### CONFIGURAZIONE SEDILI

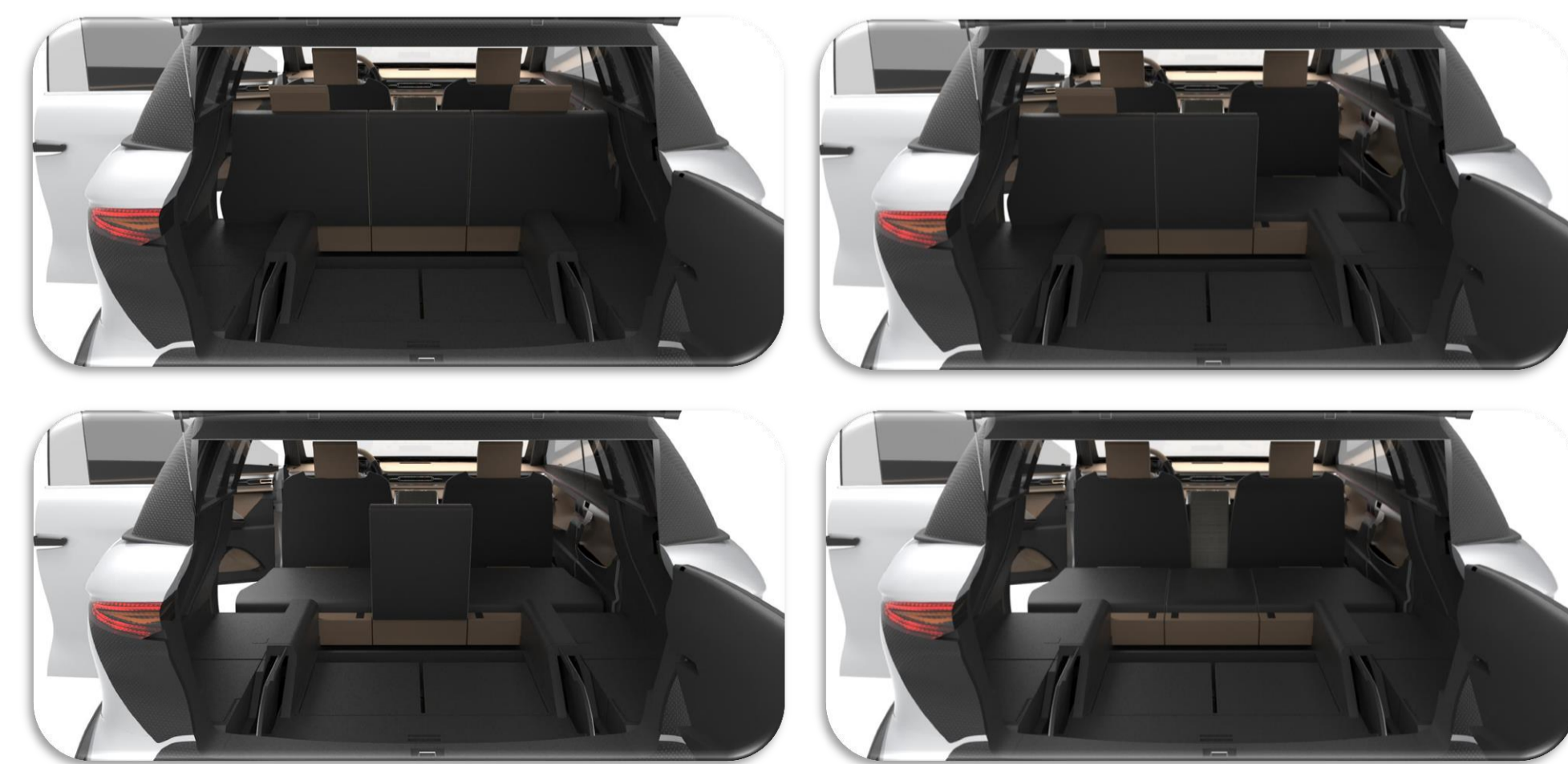



**MUV**  
CONFIGURAZIONI

**MUV CROSSOVER**  
SPAZI DIVERSI STESSA PERSONALITÀ



1810mm



1615mm



4585mm

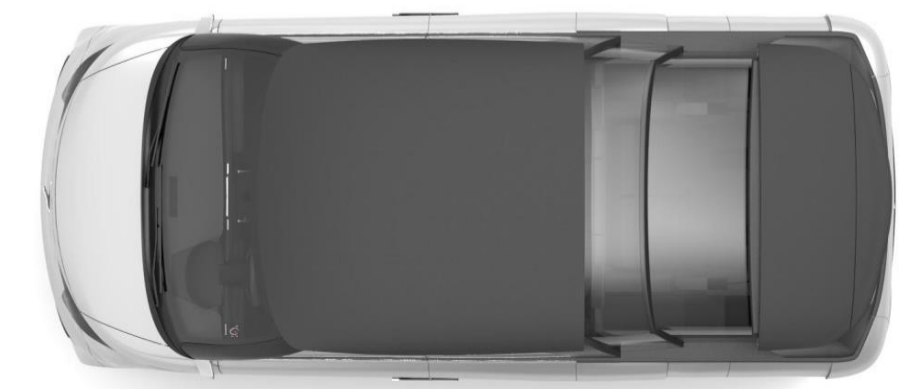



# MUV

ACCESSIBILITÀ CROSSOVER

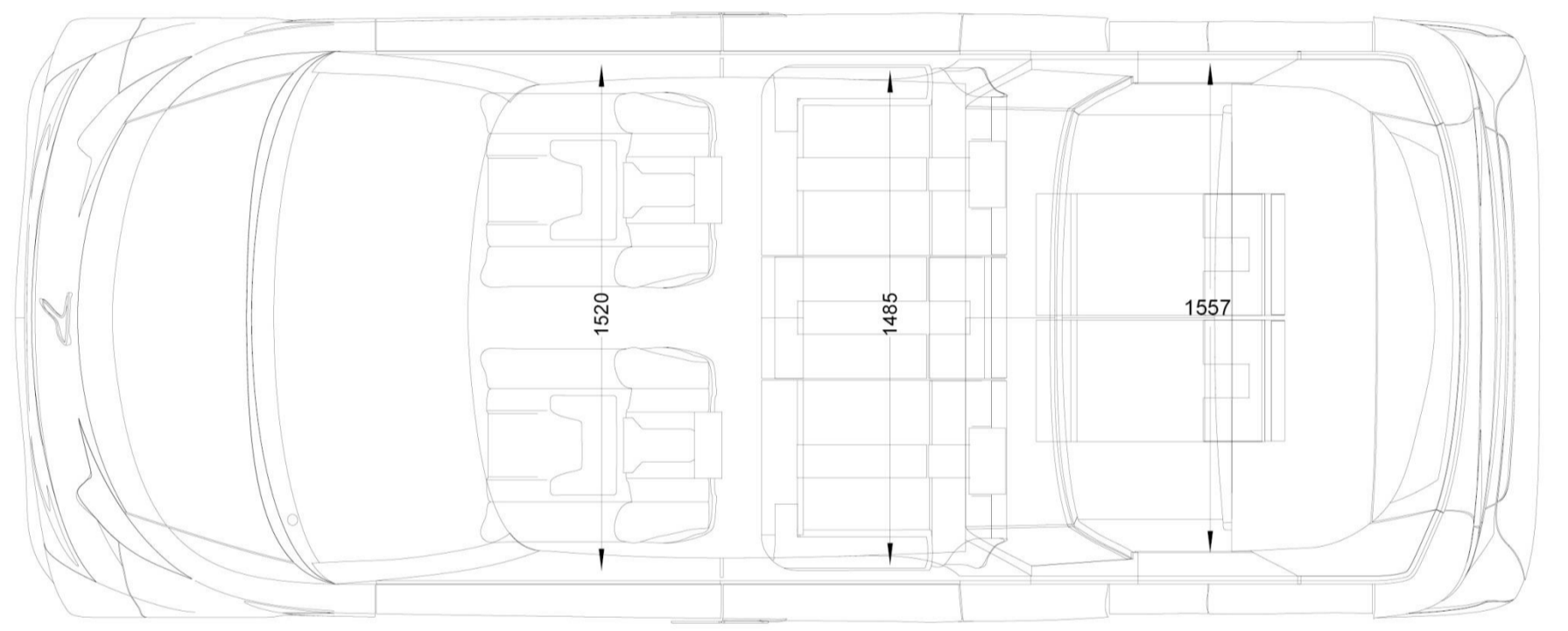
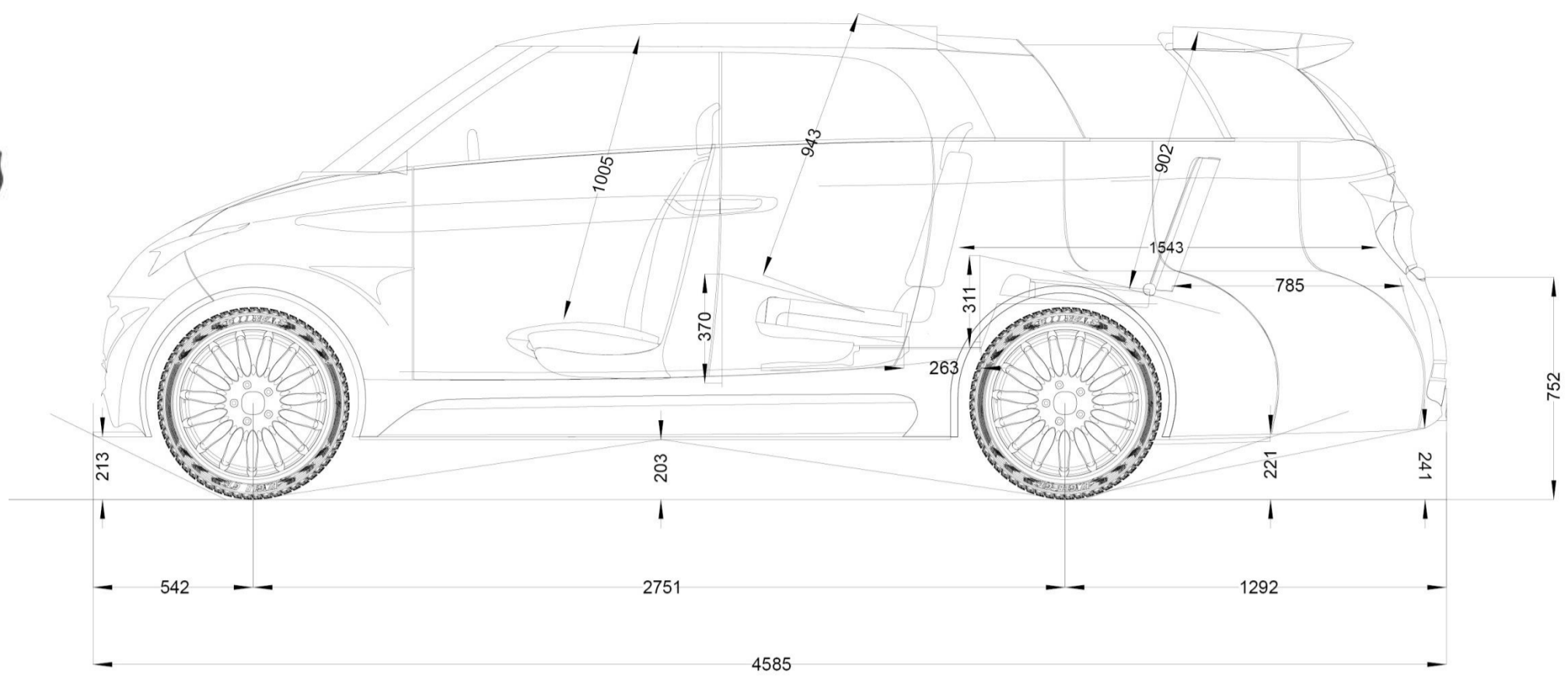
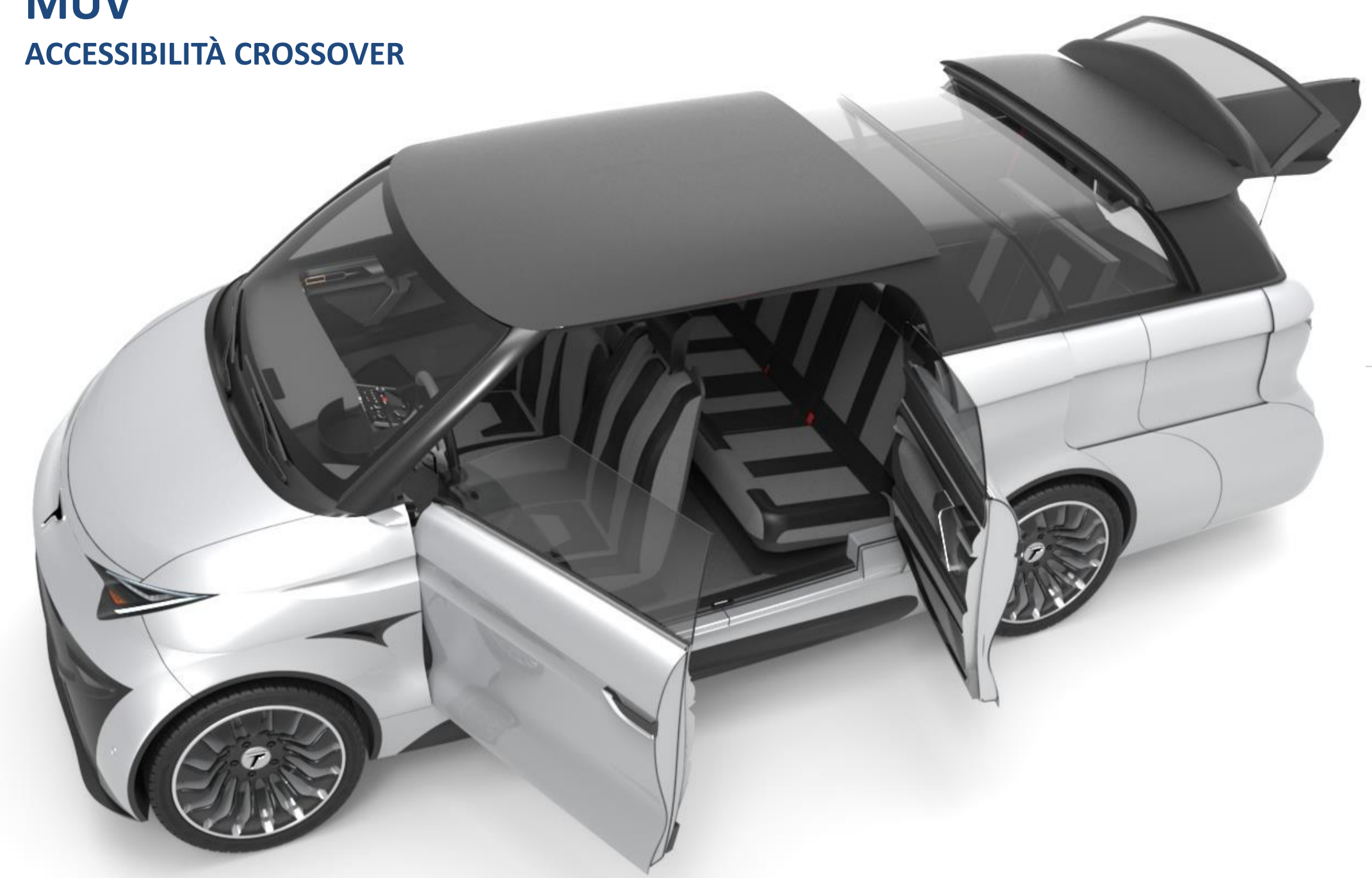

## CONFIGURAZIONE SEDILI

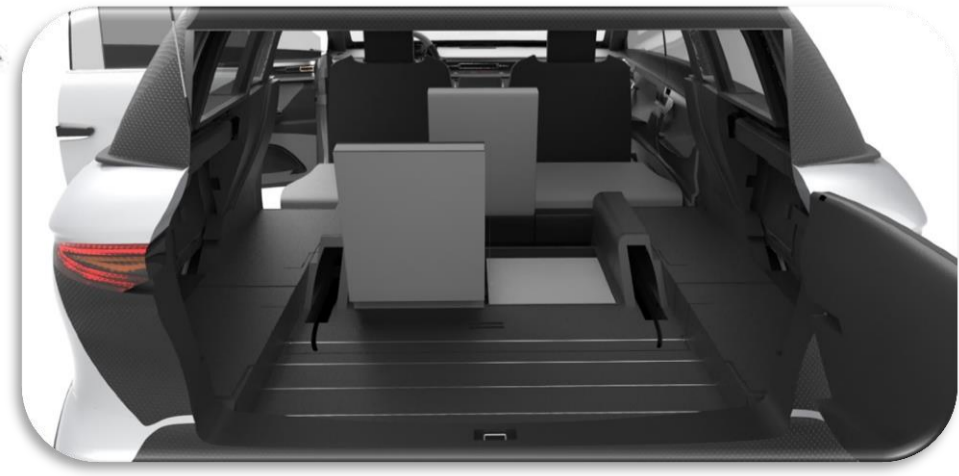
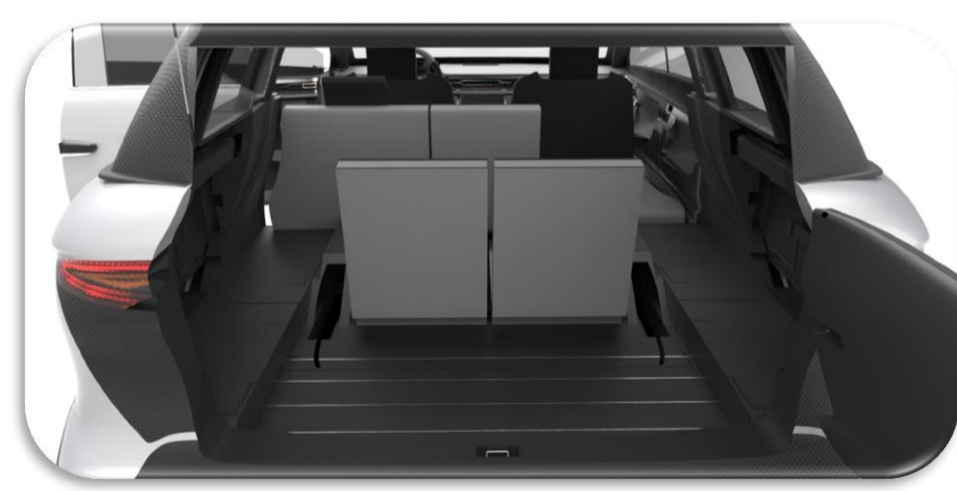

MUV  
CONFIGURAZIONI



MUV PICK UP  
SMALL - MEDIUM - LONG



4086mm



4585mm



4585mm

# MUV

ACCESSIBILITÀ PICK UP SMALL

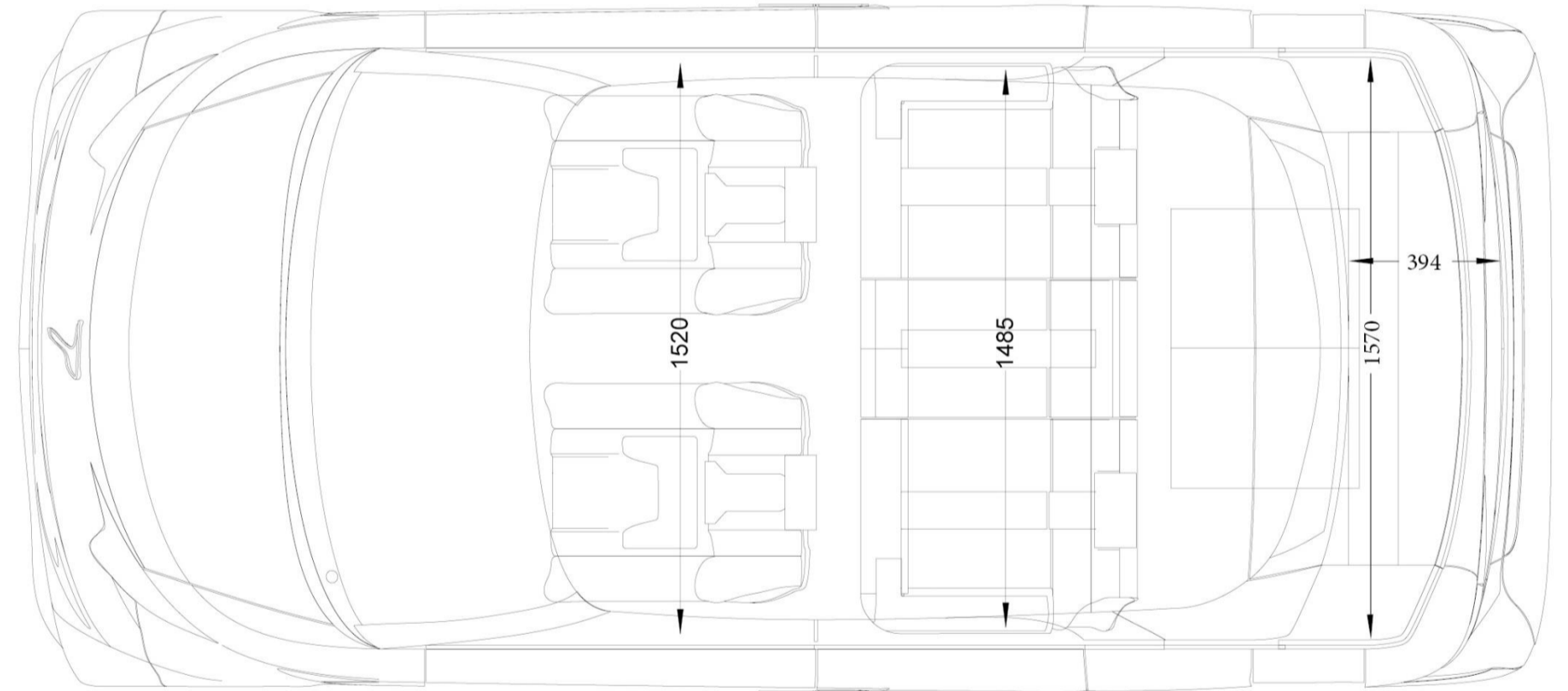
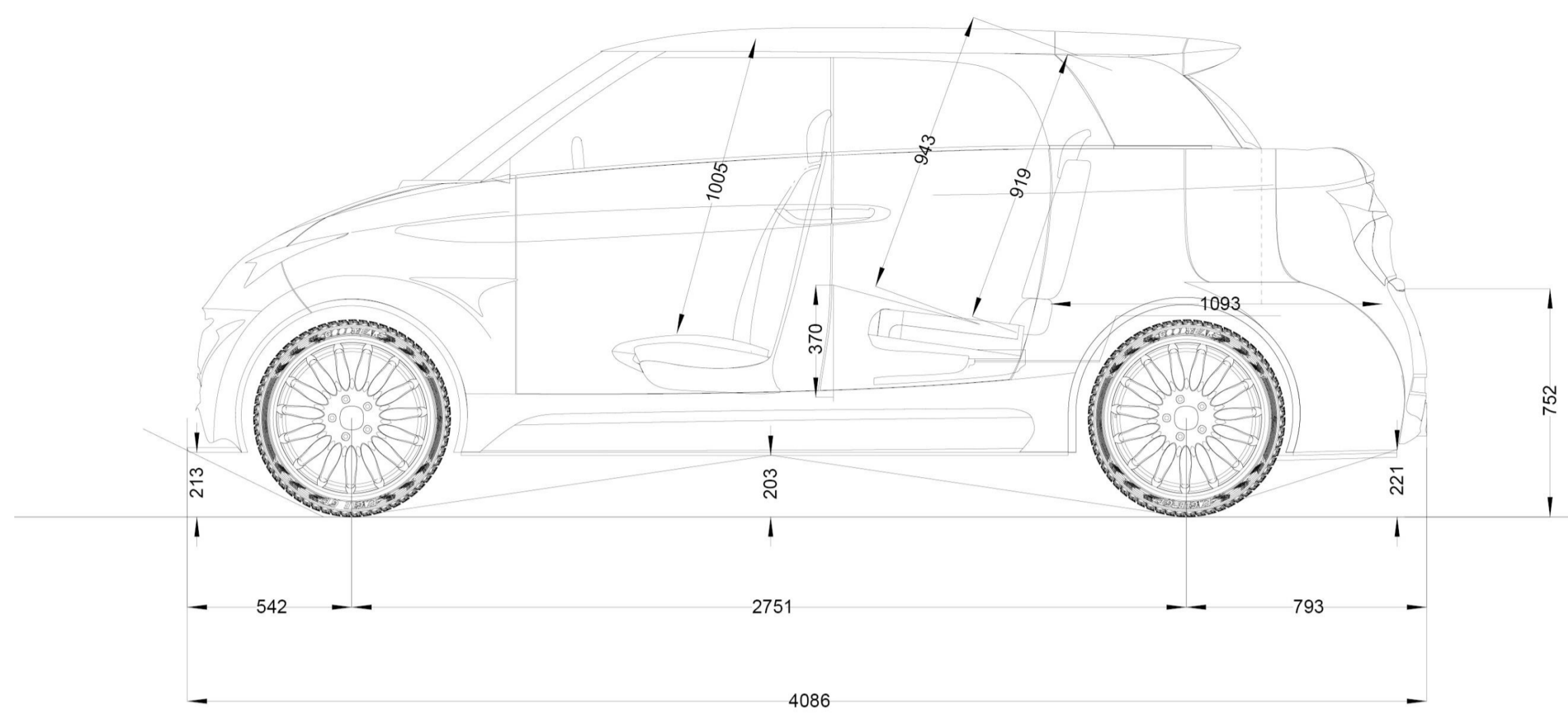

# MUV

ACCESSIBILITÀ PICK UP MEDIUM

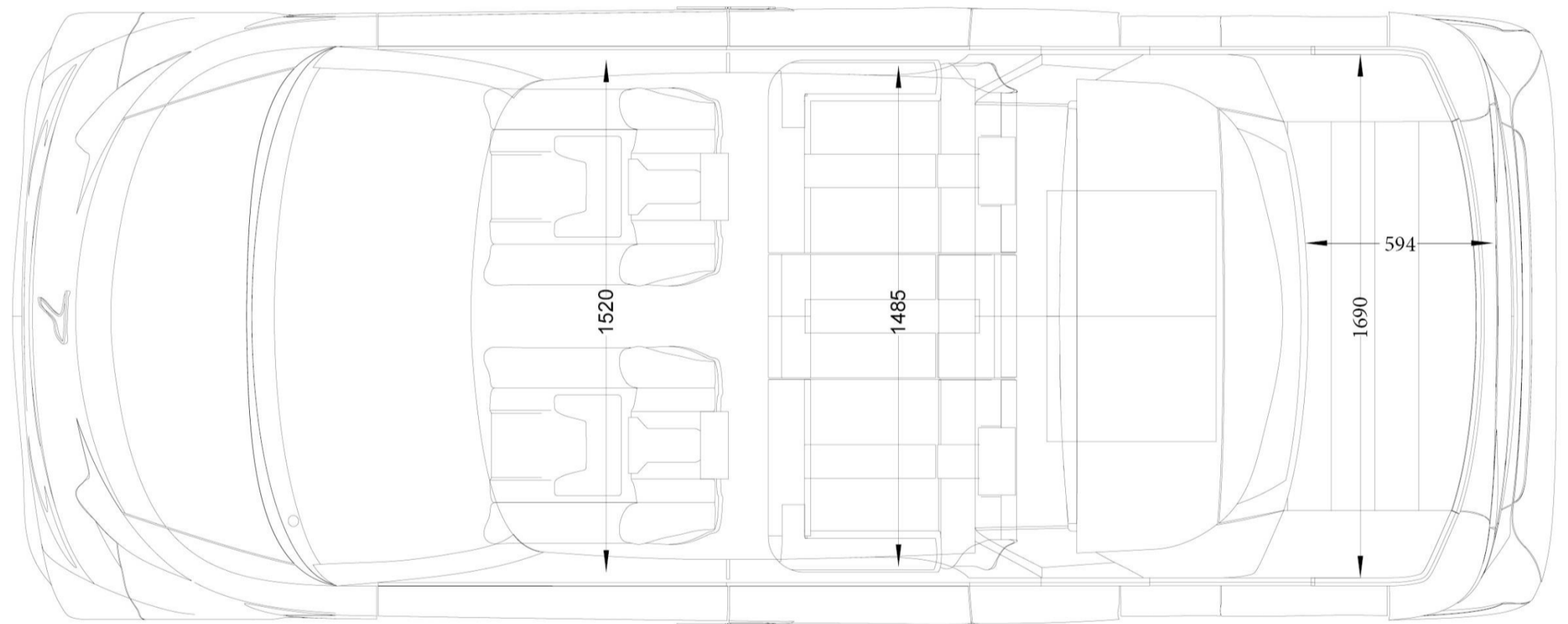
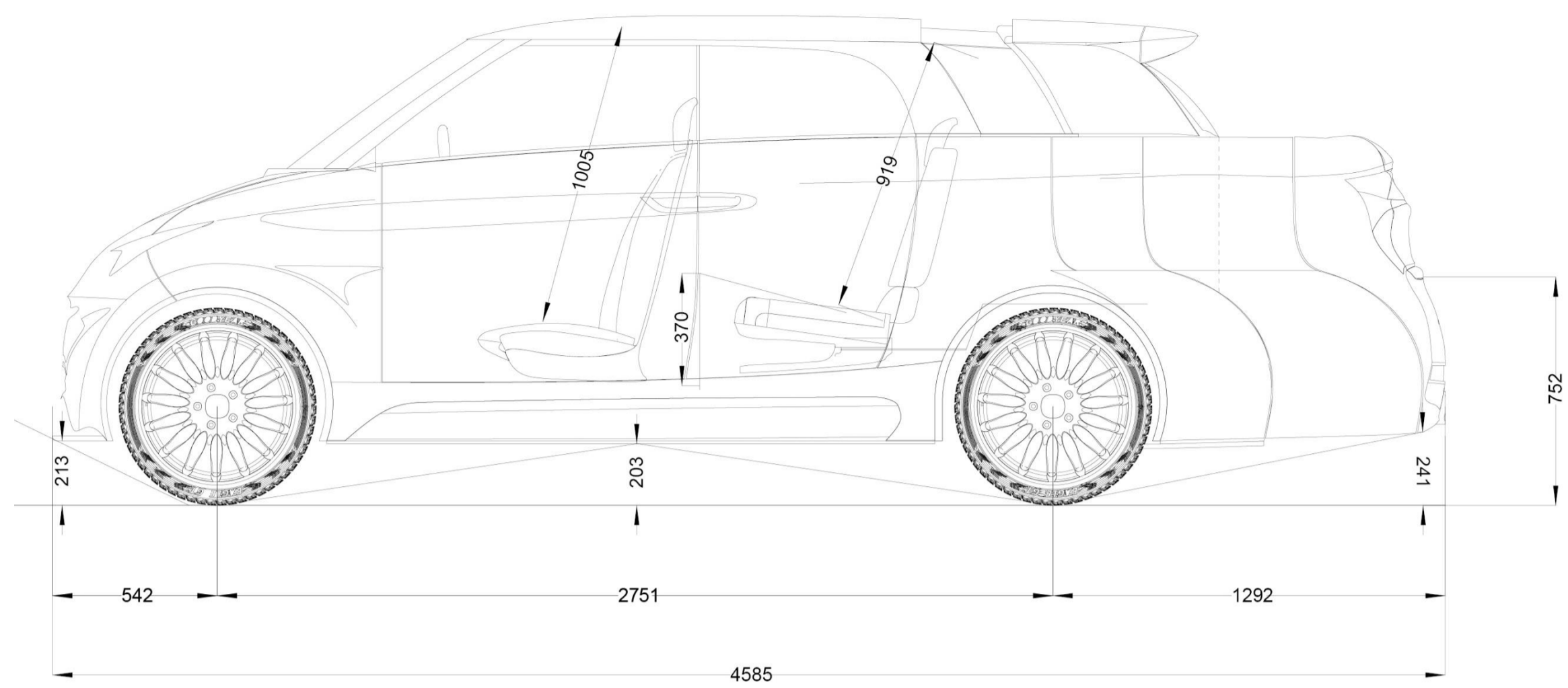
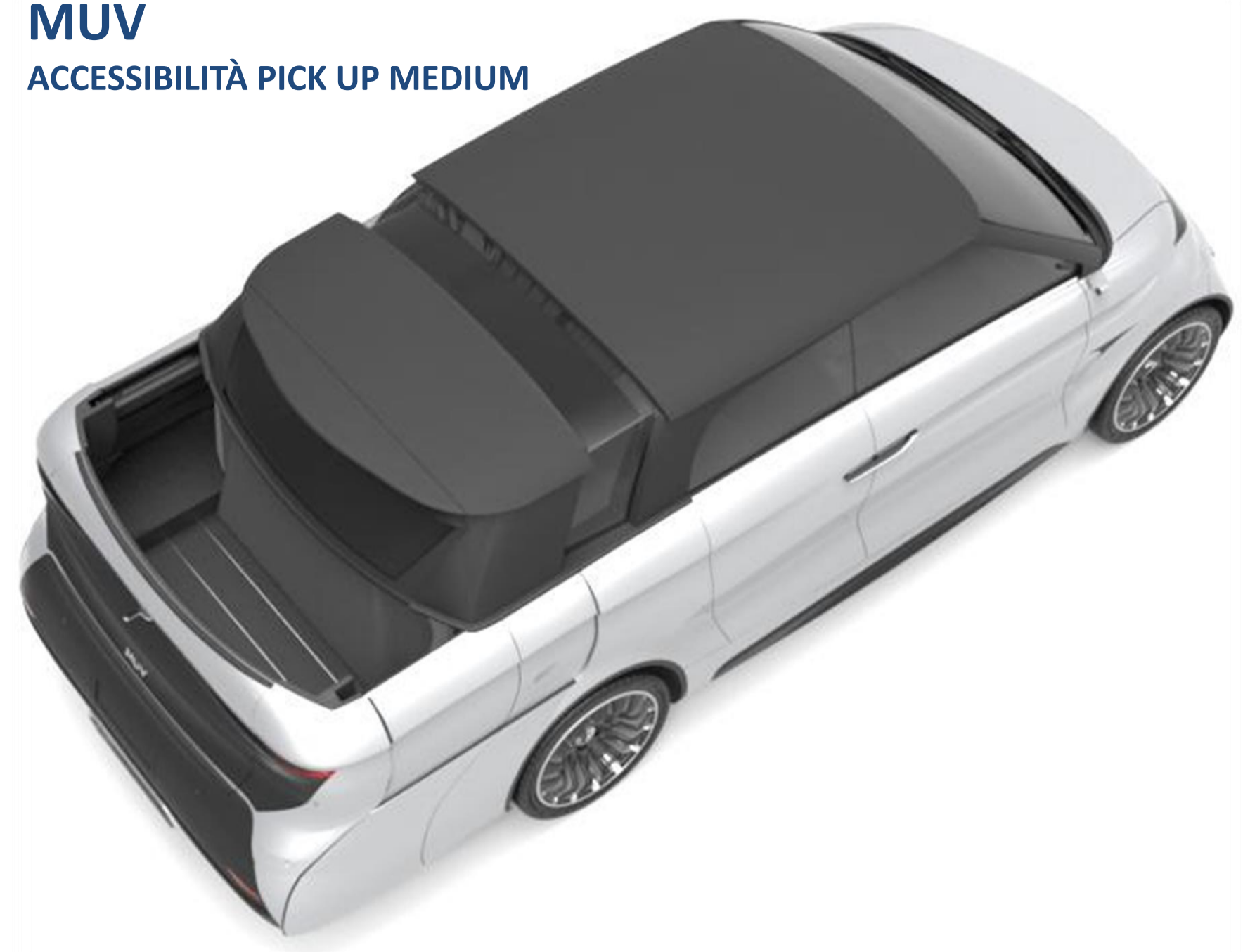

# MUV

ACCESSIBILITÀ PICK UP LONG

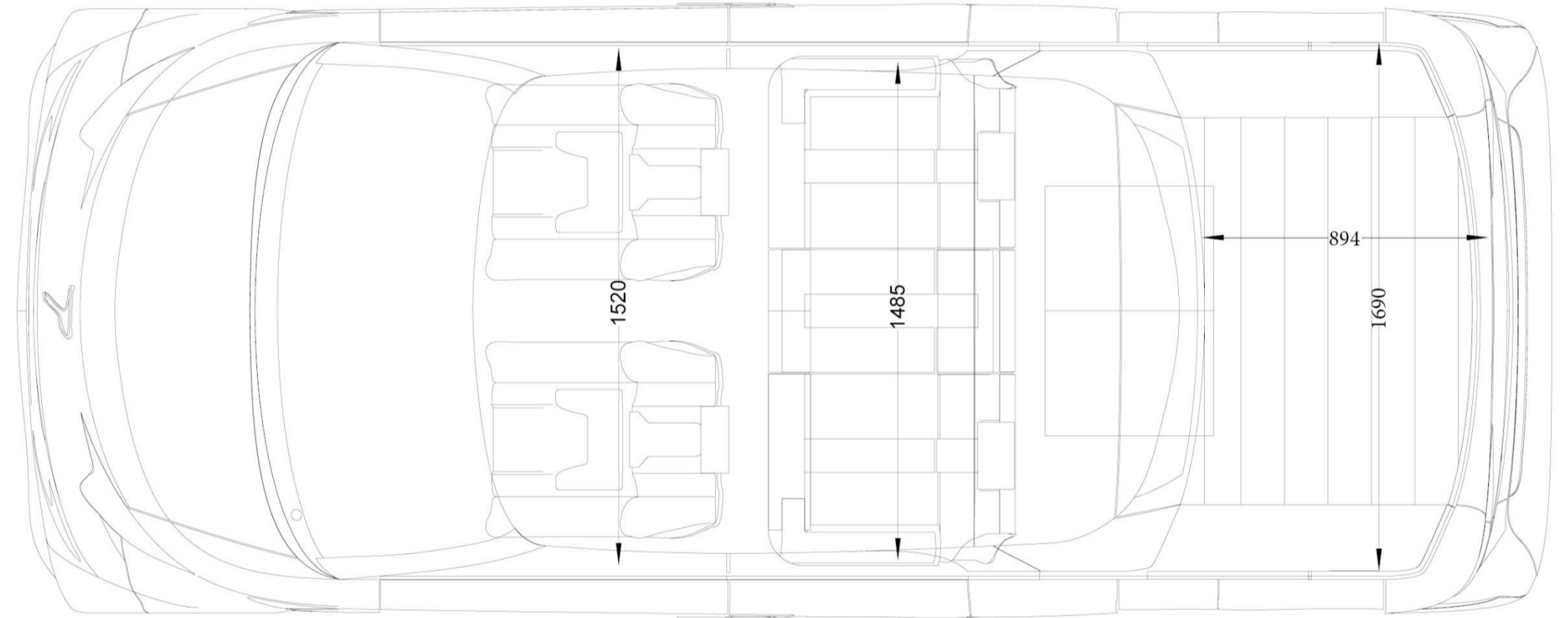
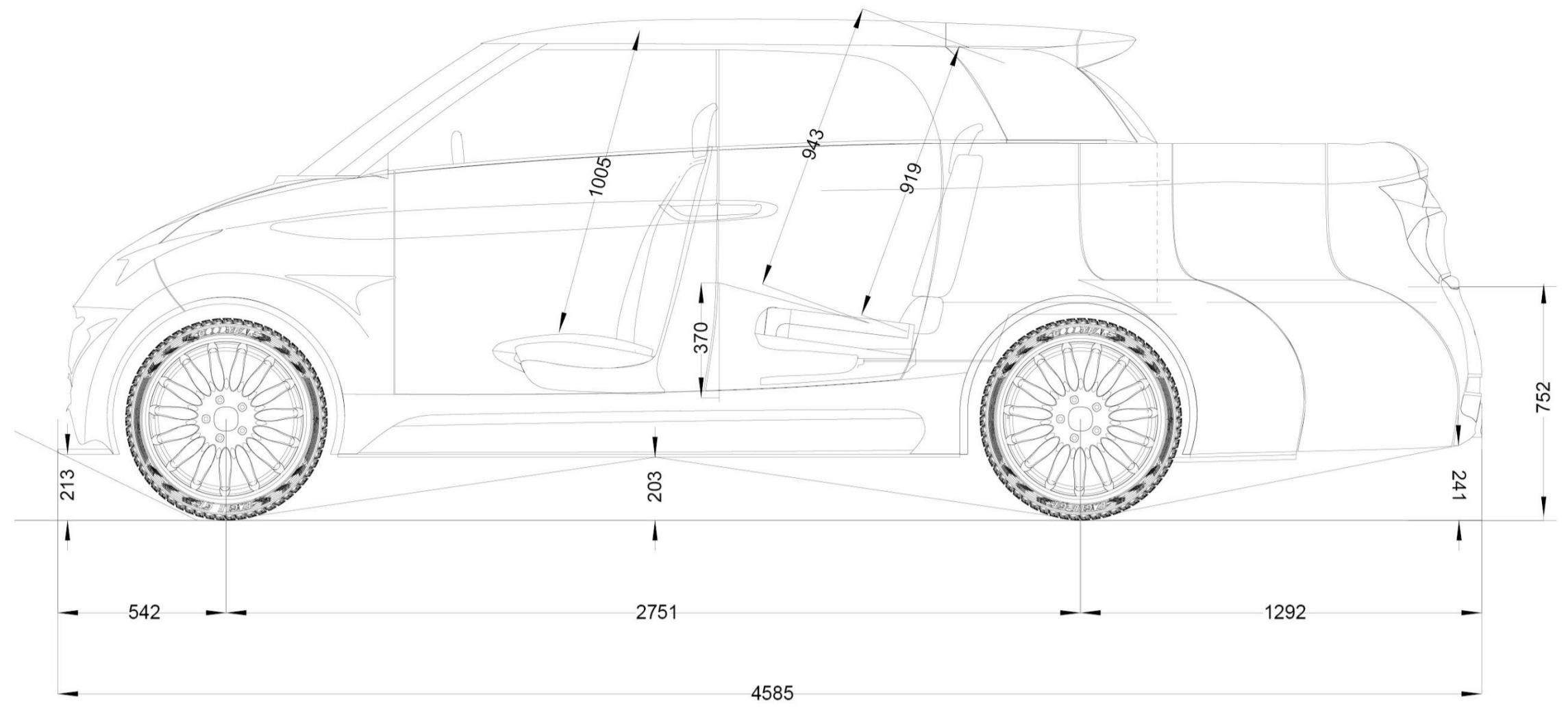

**MUV**  
CAPACITÀ DI CARICO PICK UP

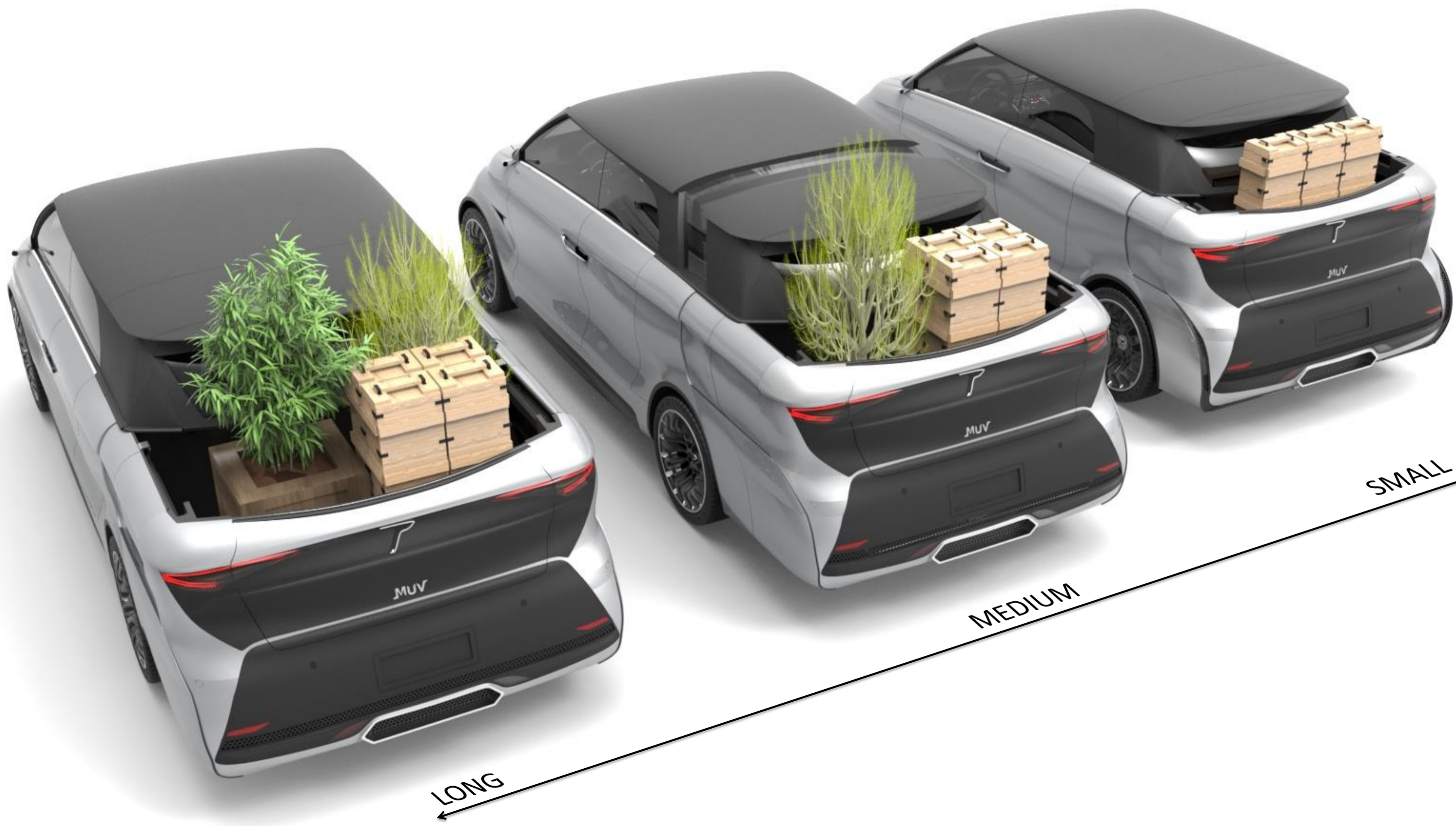



FREE LIFE

FAMILY

WORK



**AMOLED CURVE DRIVE**

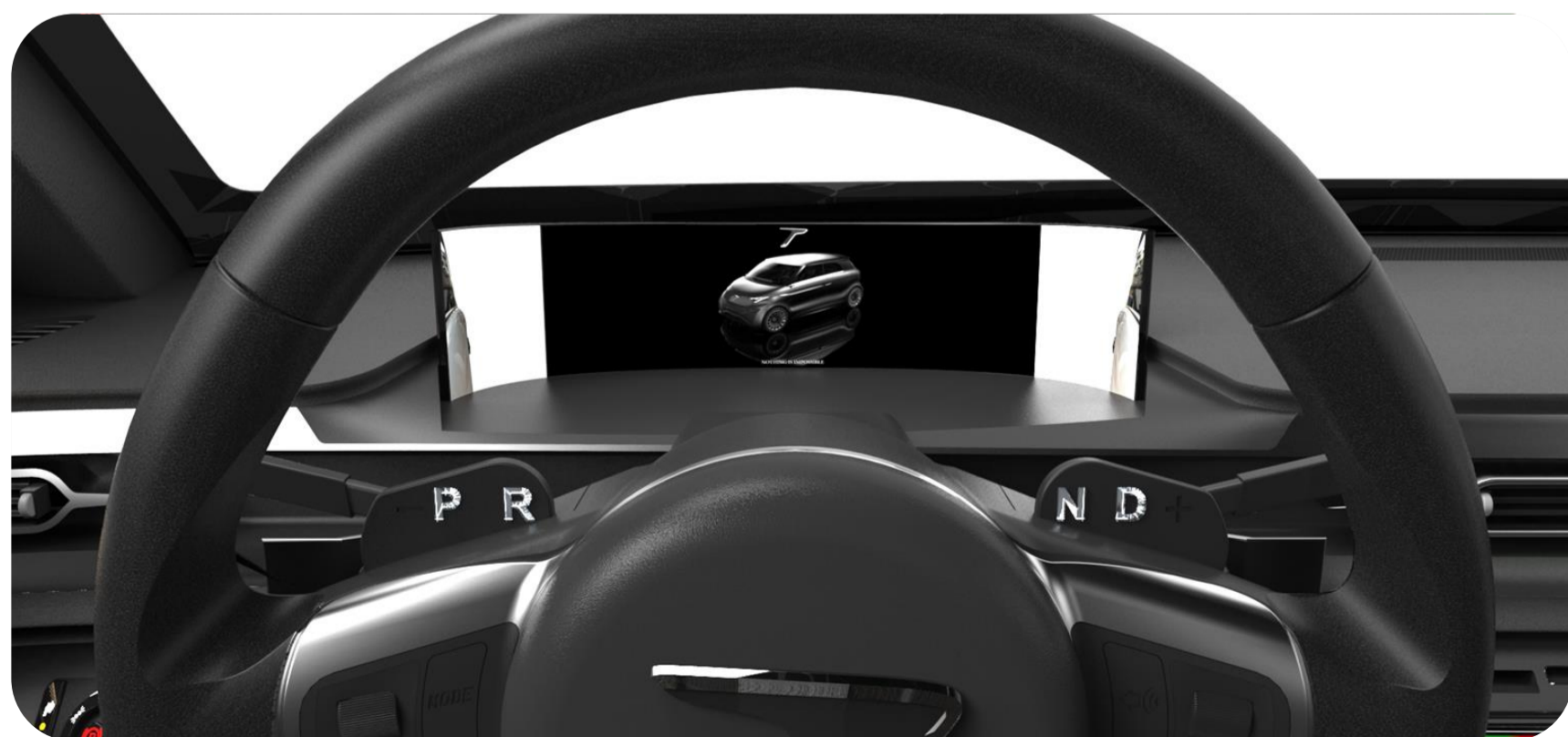

**AMOLED PLUS**





AMOLED CURVE DRIVE

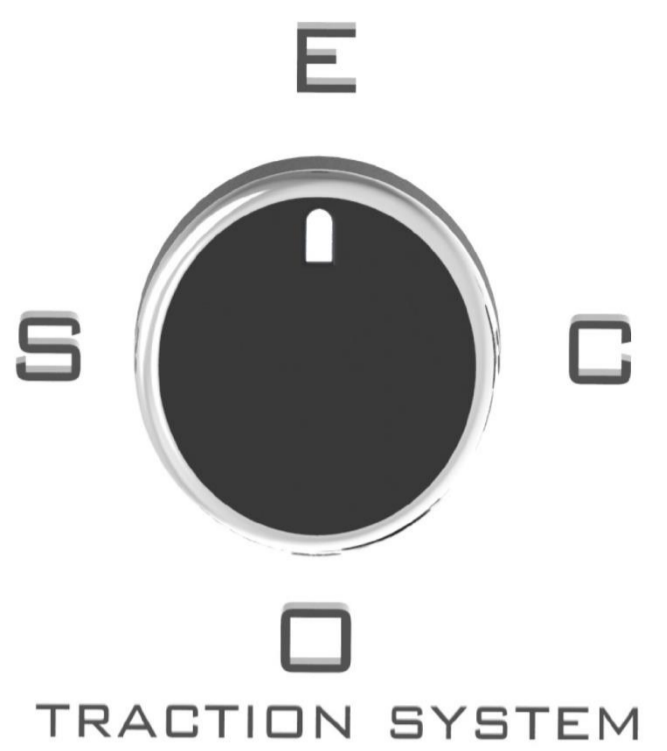

ECO



COMFORT



OFF ROAD



SPORT



AMOLED PLUS



Domenica 31/07/2016 15:00 Temperatura: 25 °C

NAVI MEDIA PHONE **CAR** BROWSER CLIMA APP/METEO

SOSPENSIONI: HIGH, LOW, SOFT, MEDIUM, HARD

COMPACT ECOS

PRESSIONE GOMME: 2.0, 2.0, 2.0, 2.0

CITY CROSSOVER

CITY PICK UP

SPORT COMFORT

OFF ROAD

SELECT MODE

BACK MENU

Consumo istantaneo:  
Consumo medio:  
Velocità media: 40 Km/h  
Trip.A Km percorsi: 150 Km  
Rigenerazione %:

01 - I Want You Back

Domenica 31/07/2016 15:00 Temperatura: 25 °C

NAVI **MEDIA** PHONE CAR BROWSER CLIMA APP/METEO

USB CARTELLE

Michael Jackson LIST.

- 01 - I Want You Back
- 02 - ABC
- 03 - The Love You Save
- 04 - Got To Be There
- 05 - Rockin' Robin
- 06 - Ben
- 07 - Enjoy Yourself
- 08 - Blame It On The Boogie
- 09 - Shake Your Body (Down To The...
- 10 - Don't Stop 'Til You Get Enou..
- 11 - Rock With You
- 12 - Off The Wall
- 13 - She's Out Of My Life
- 14 - Can You Feel It
- 15 - The Girl Is Mine
- 16 - Billie Jean
- 17 - Beat It
- 18 - Wanna Be Startin' Somethin'

01 - I Want You Back

00:35 05:25

ROMA Domenica 31 Luglio 27°C 17°  
Soleggiato sereno

Lun	Mar	Mer	Gio	Ven	Sab	Dom
01/08	02/08	03/08	04/08	05/08	06/08	07/08
27°/18°	26°/16°	24°/16°	24°/16°	25°/16°	27°/18°	28°/19°

APP: AUTOVELOX, BUSSOLA, TRIPADVISOR, GMAIL

CLIMA: 18°, 3, 16°

BACK MENU



**MUV**  
TELAIO E COMPONENTI



TELAIO LATERALE MOBILE

TELAIO INFERIORE FISSO

TELAIO MONOSCOCCA FISSO

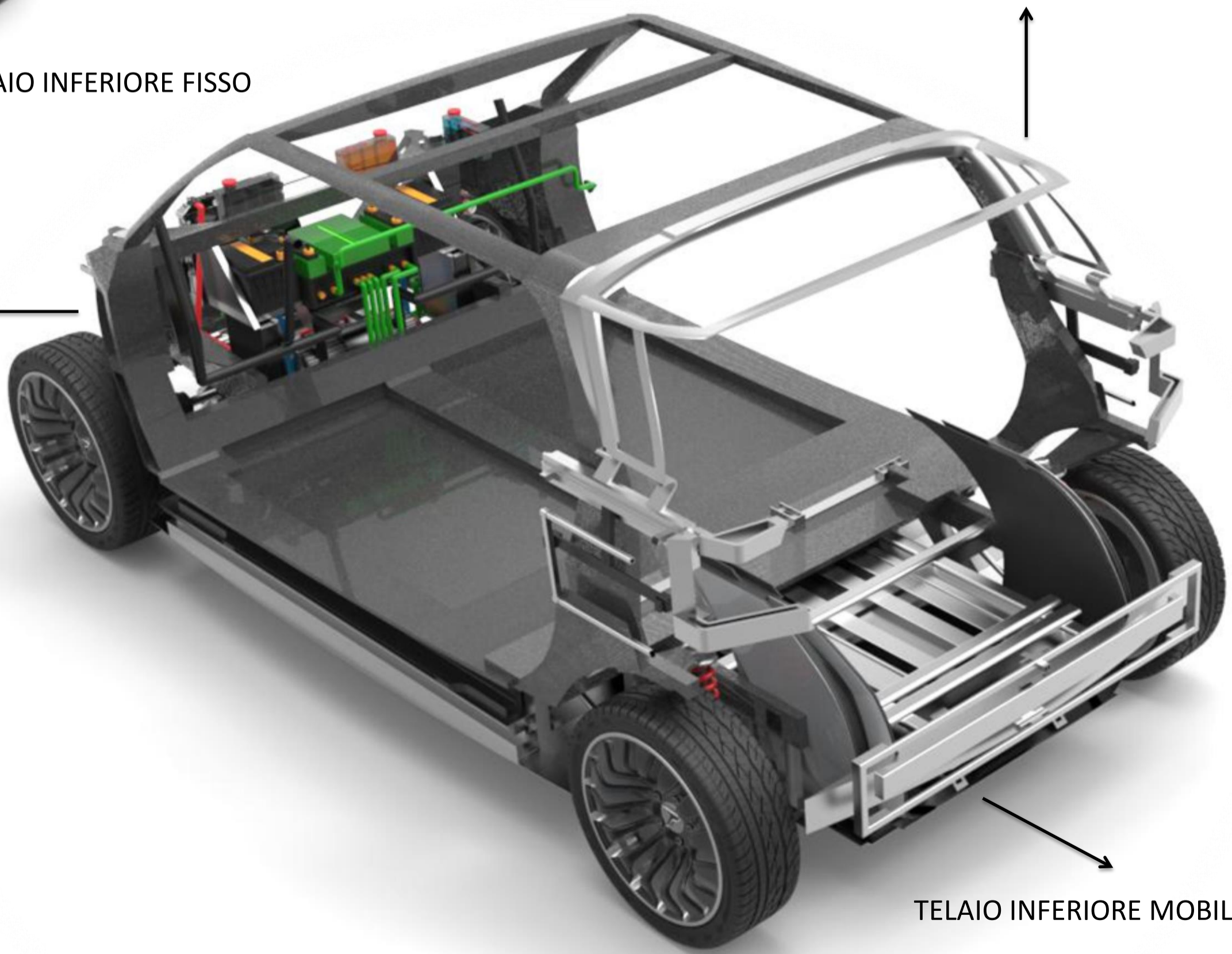

TELAIO SUPERIORE MOBILE

TELAIO INFERIORE MOBILE

# MUV

MOTORI E BATTERIE

MOTORE ANTERIORE

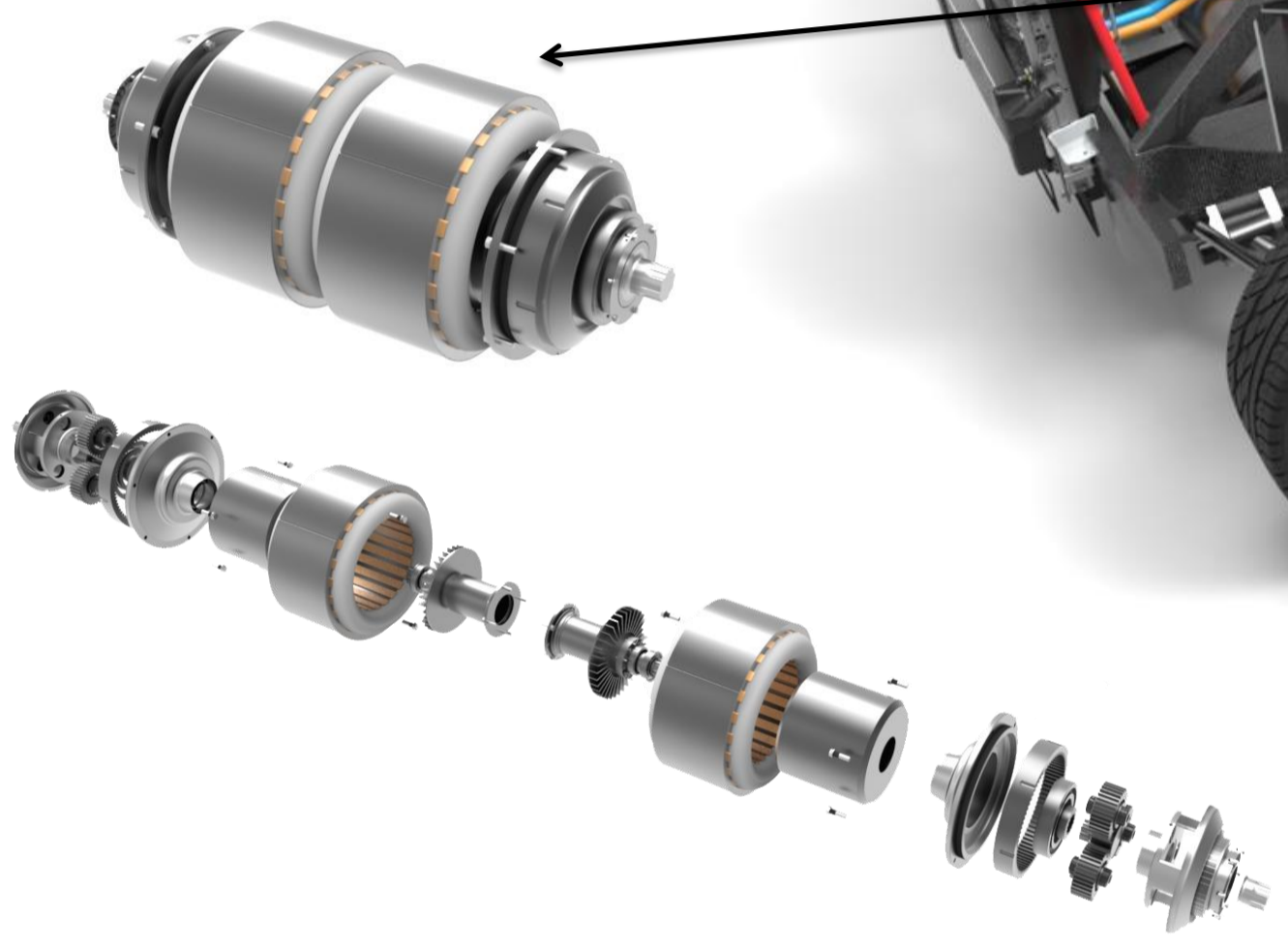

MOTORE POSTERIORE  
OPZIONALE

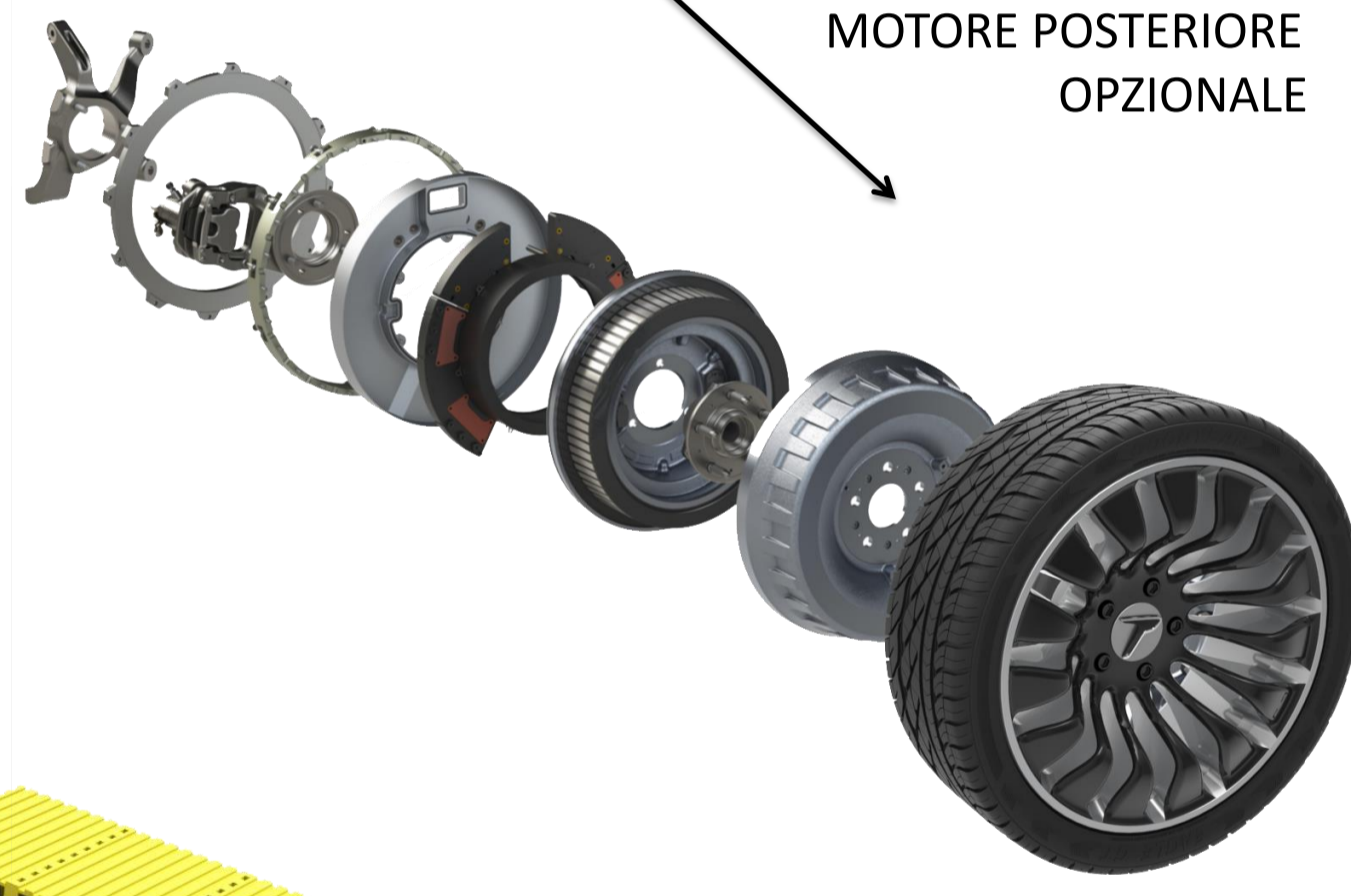

BATTERIE

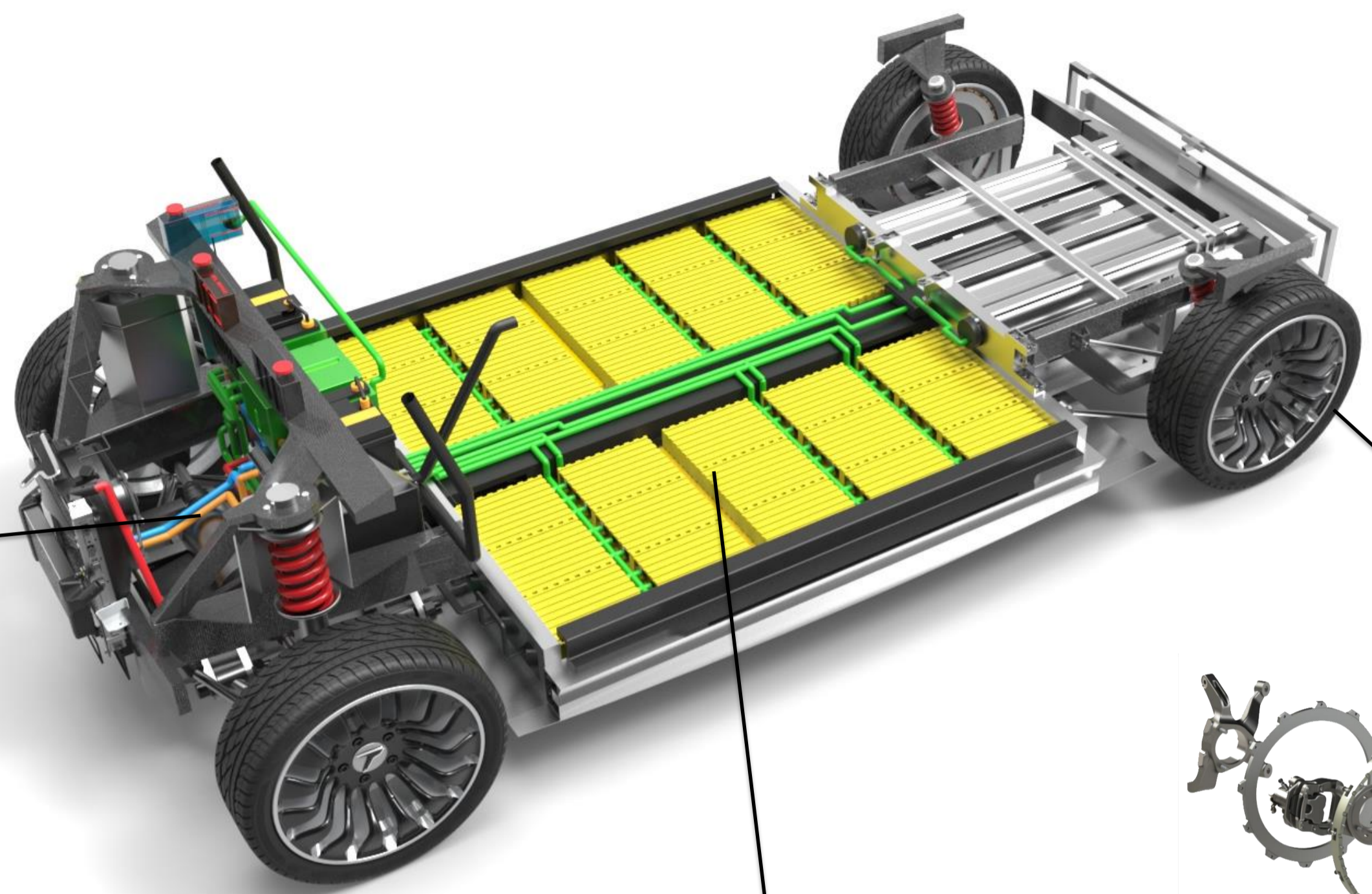
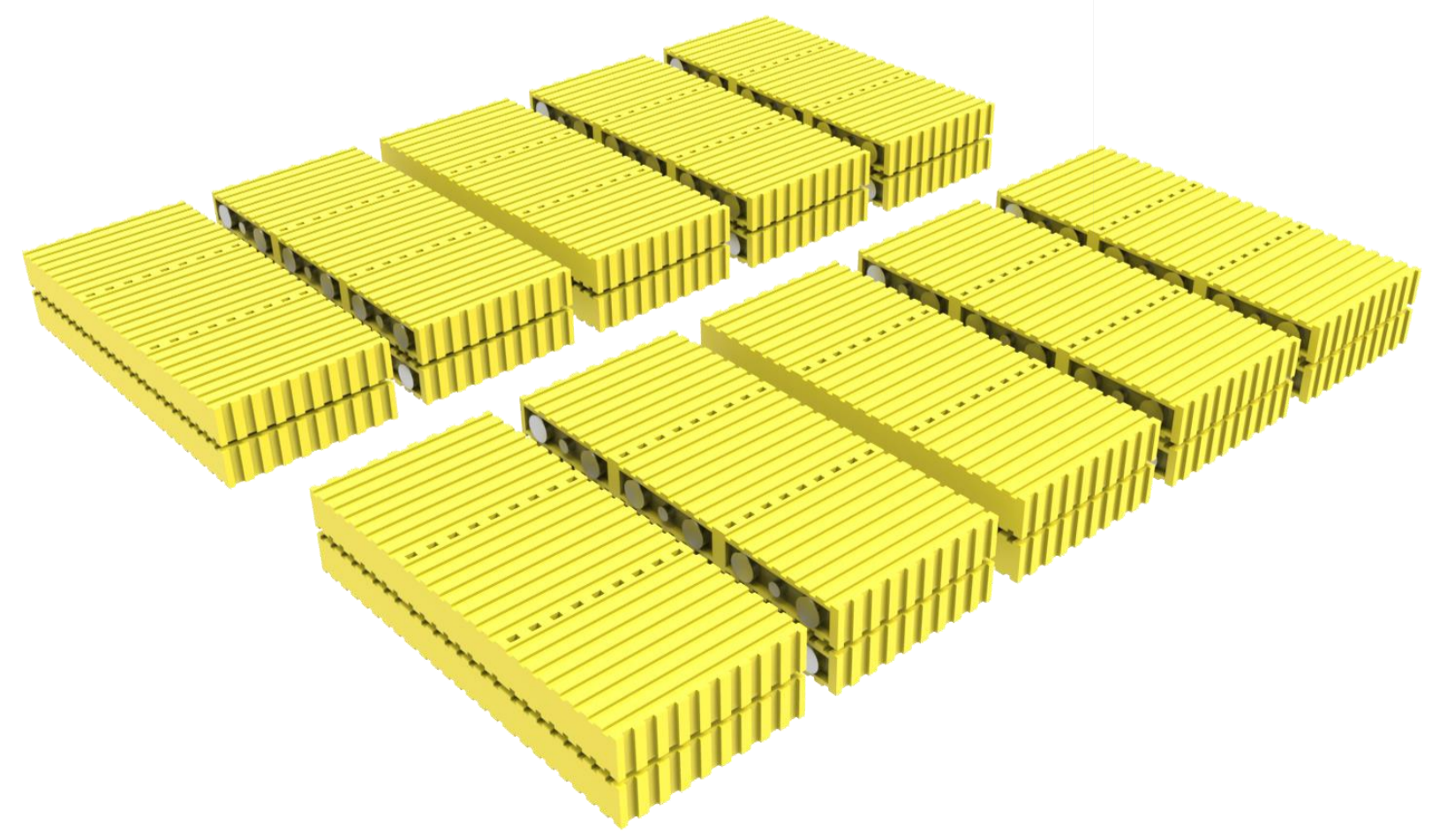

**MUV**  
**ESPLOSO TELAIO E COMPONENTI**

CELLULA ABITACOLO:  
 TELAIO IN FIBRA DI CARBONIO

ATTACCO PER SCOCCA POLICARBONATO :  
 MATERIALE ALLUMINIO

TELAIO MODULO SUPERIORE  
 MATERIALE ALLUMINIO

TELAIO MODULI CENTRALI LATERALI :  
 MATERIALE ALLUMINIO

TELAIO MODULO POSTERIORE :  
 MATERIALE ALLUMINIO

TELAIO MODULO INFERIORE :  
 MATERIALE ALLUMINIO

TELAIO DI SUPPORTO CELLULA ABITACOLO  
 IN ALLUMINIO E COLLEGAMENTO A GRUPPO  
 SOSPENSIONI, SERVOSTERZO E FRENI

MOTORI POSTERIORI (OPZIONALI)

SISTEMA DI RAFFREDDAMENTO PASSIVO :  
 CONDOTTI ESPULSIONE CALORE BATTERIE

VANO BATTERIE E KARTER DI SUPPORTO :  
 TELAIO IN ALLUMINIO

CENTRALINA CENTRALE E COLLEGAMENTI

CONDOTTI DI ESPULSIONE ARIA  
 RAFFREDDAMENTO PASSIVO MOTORE ELETTRICO

SISTEMA DI RAFFREDDAMENTO PASSIVO  
 MOTORE ELETTRICO

ATTUATORI PNEUMATICI E COLLEGAMENTI

MOTORE ELETTRICO E CENTRALINE

GRUPPO BATTERIE

SISTEMA DI RAFFREDDAMENTO ATTIVO :  
 RADIATORE, POMPA E COLLEGAMENTI  
 CIRCUITO DI RAFFREDDAMENTO BATTERIE

ATTACCHI CAVI BATTERIE

SISTEMA DI RAFFREDDAMENTO PASSIVO :  
 INGRESSO/USCITA CONDOTTO ARIA CON PARATIE  
 DI SMISTAMENTO ARIA NEL VANO BATTERIE

USCITA

CONDOTTO D'ARIA PASSIVO ESTRAIBILE AD INCASTRO  
 PER CONFIGURAZIONI ALTERNATIVE

INGRESSO

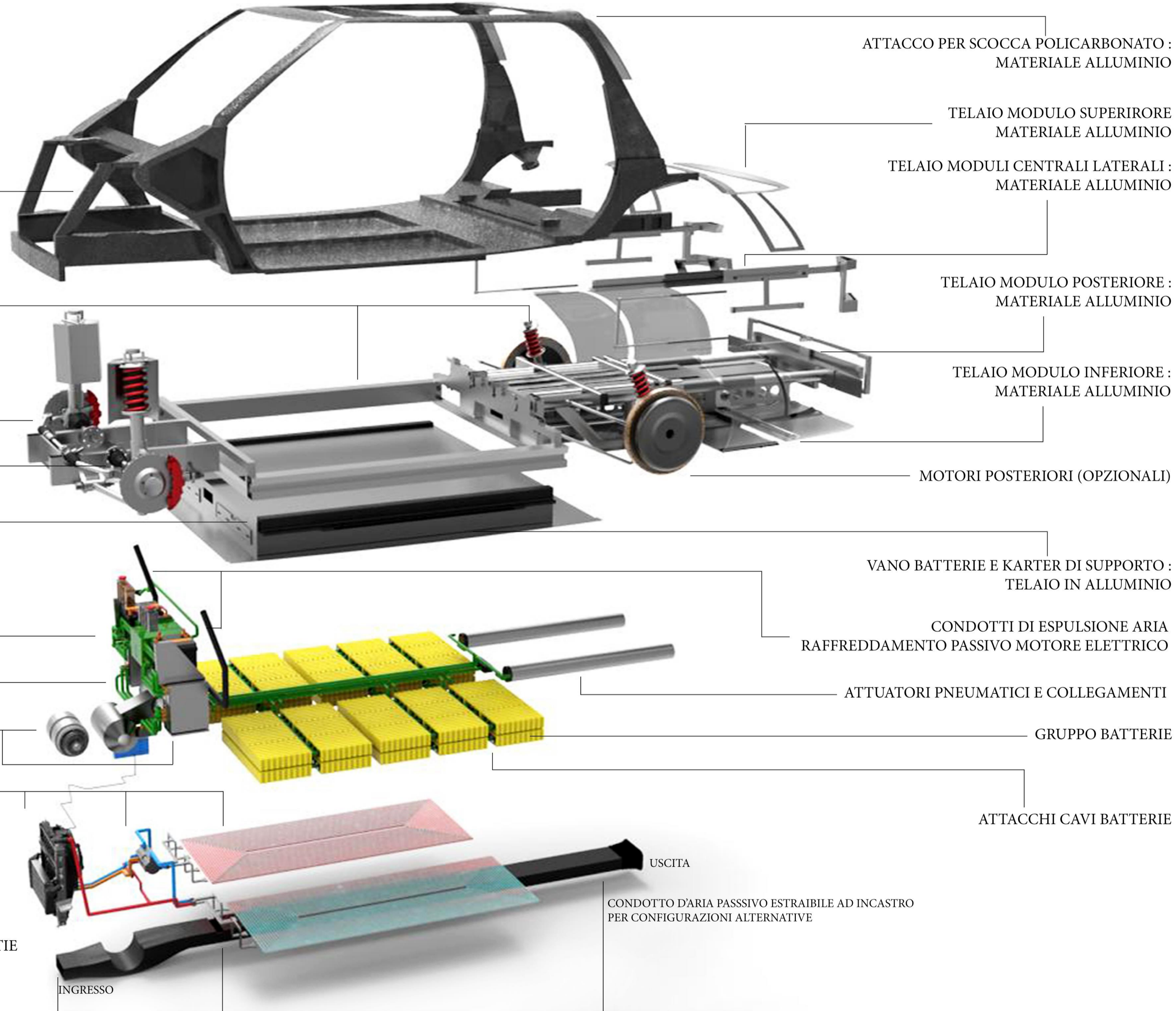

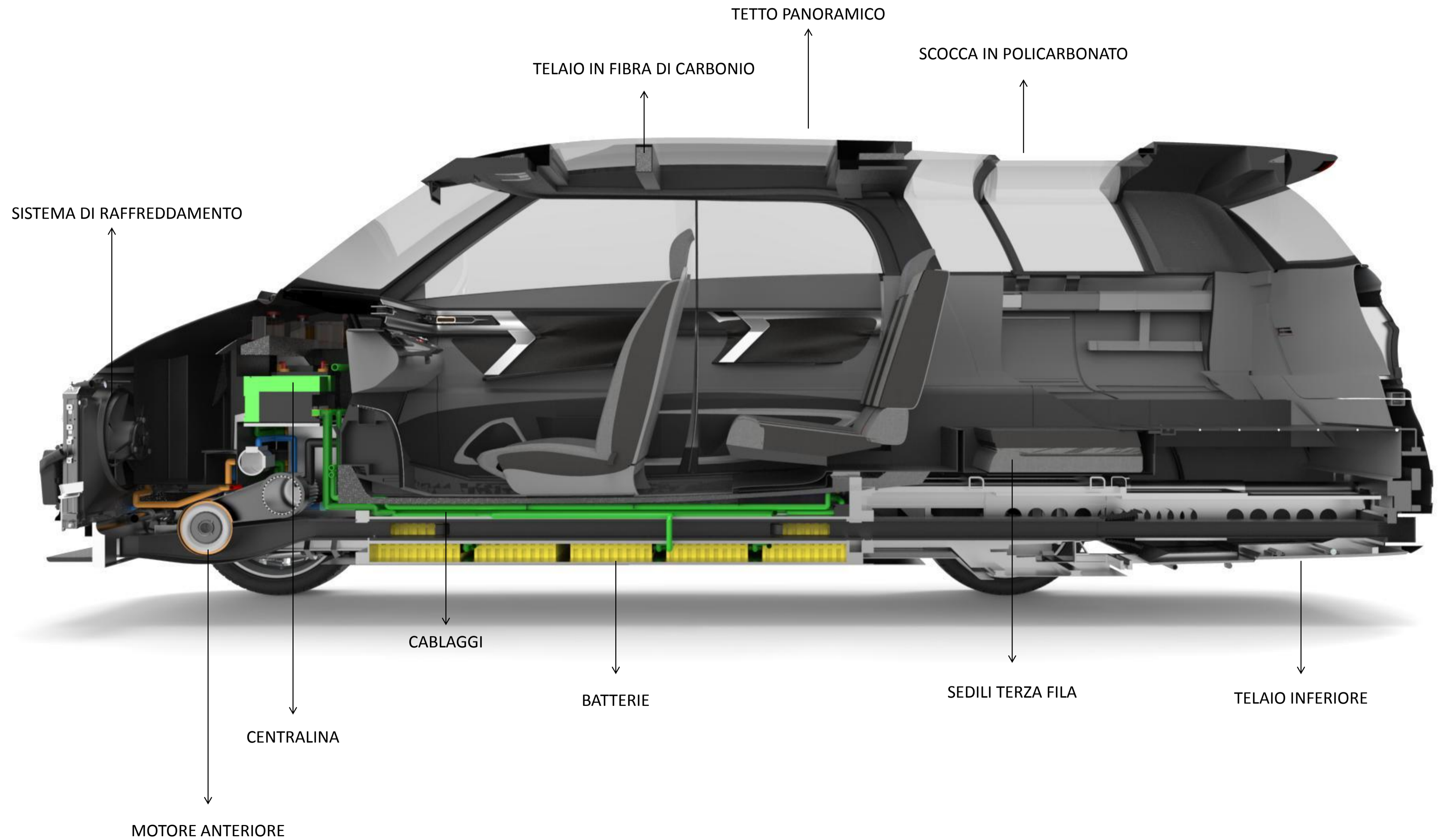

# MUV

## ESPLOSO MACROCOMPONENTI

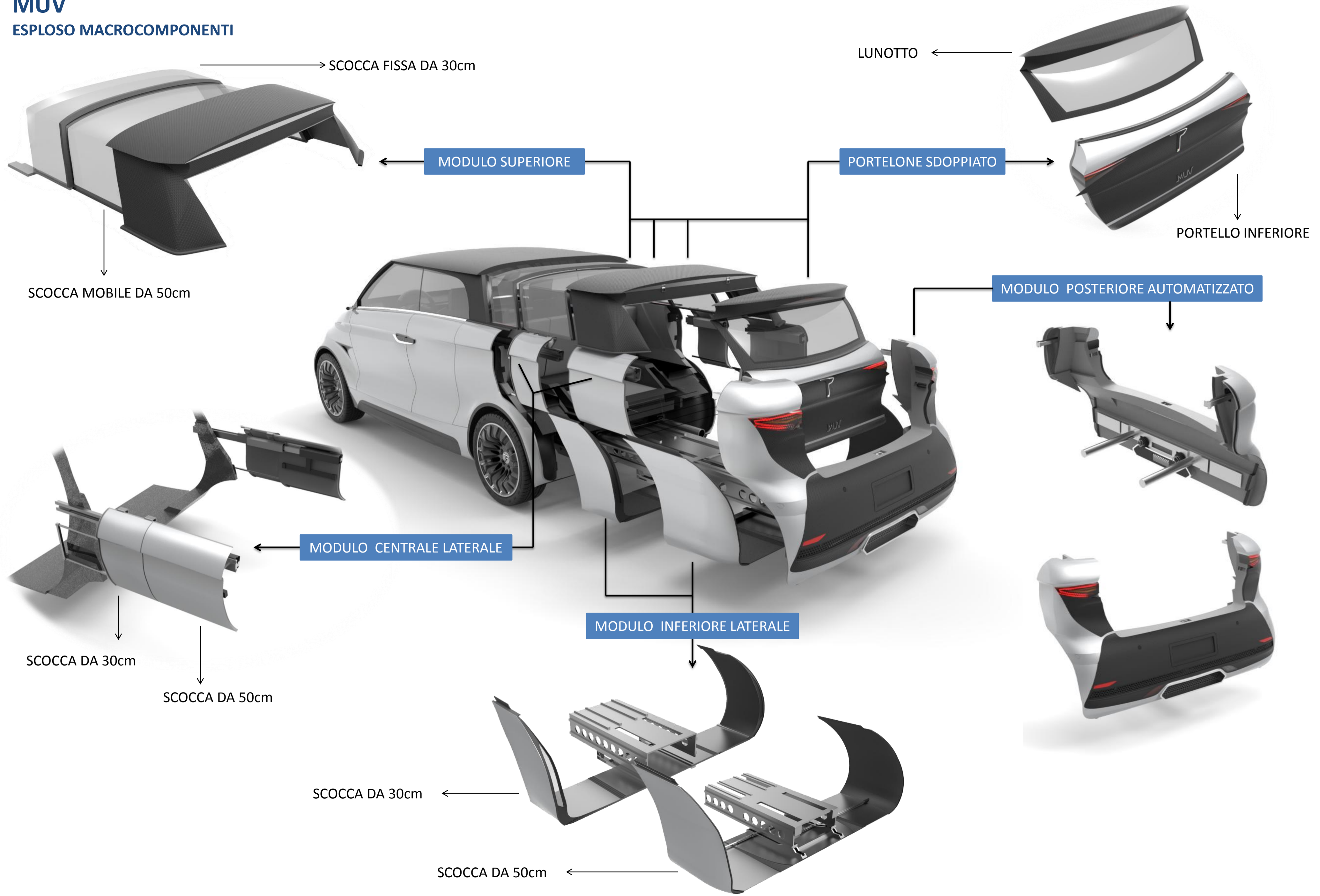



# MUV

## MACROCOMPONENTI: MODULO SUPERIORE

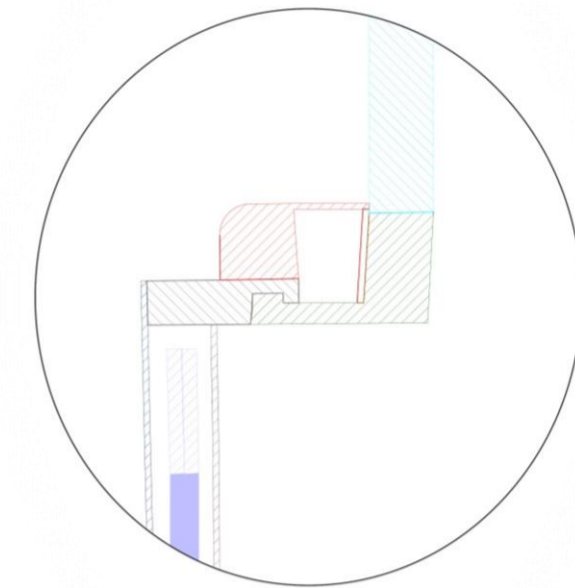
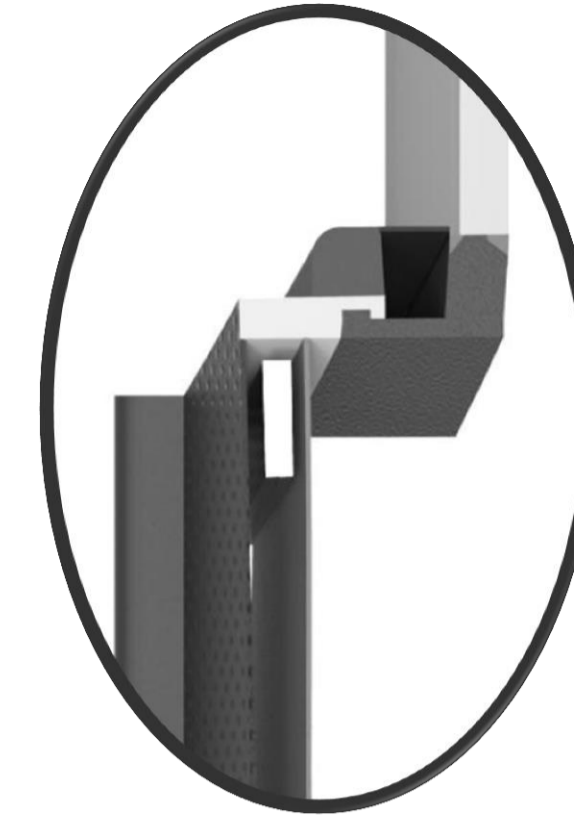
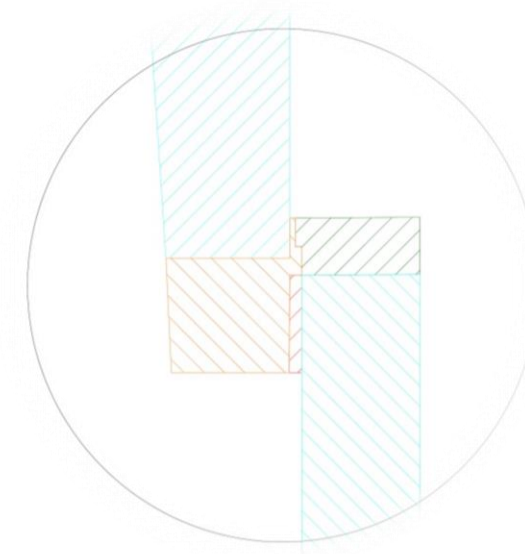
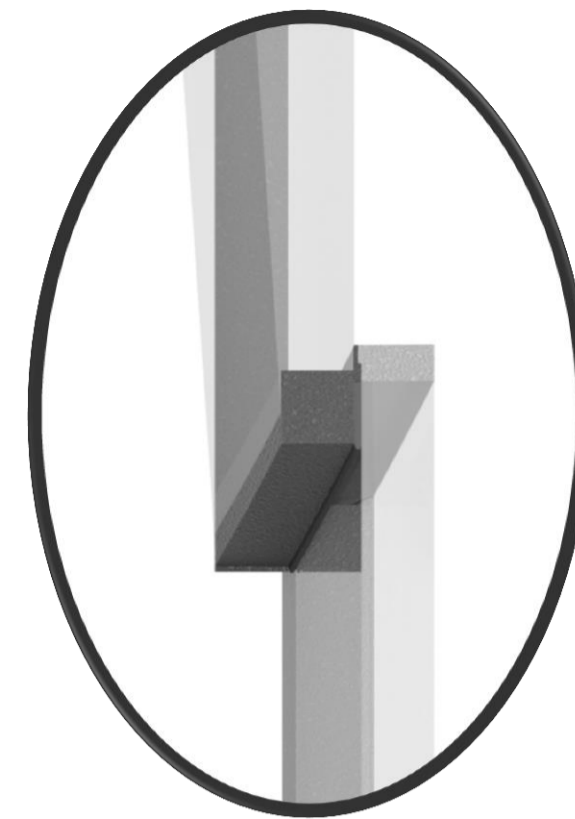

1. INCASTRO SCOCCA FISSA 30cm  
CON SCOCCA MOBILE 50cm

2. INCASTRO SCOCCA MOBILE 50cm  
CON SCOCCA MOBILE MODULO

POSIZIONE DI PARTENZA

SPOSTAMENTO SCOCCA DI 30 cm

SPOSTAMENTO SCOCCA DI 50 cm

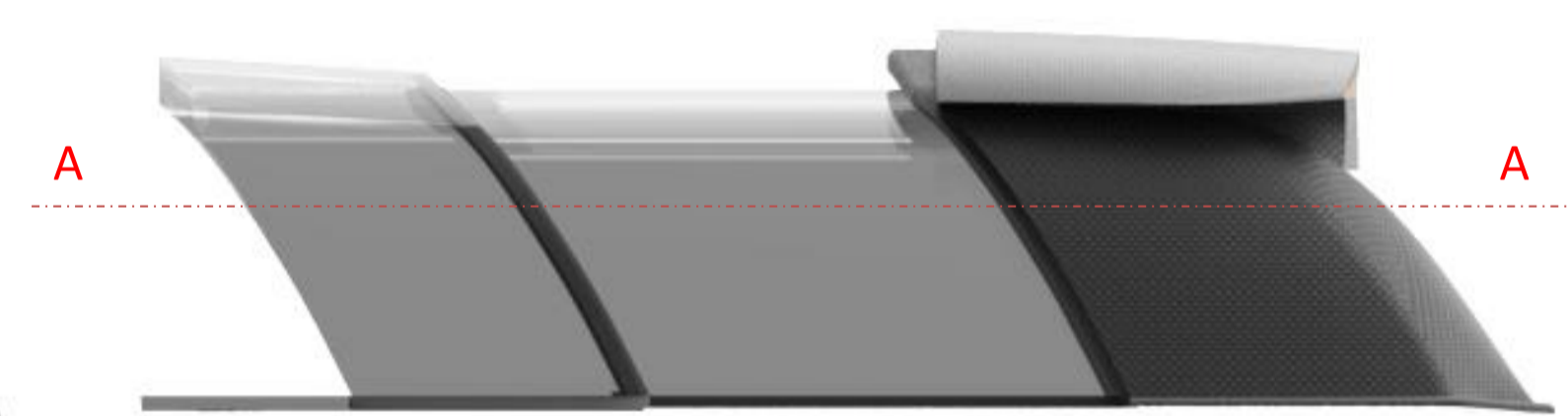

EVOLUZIONE MOVIMENTO MODULO SUPERIORE

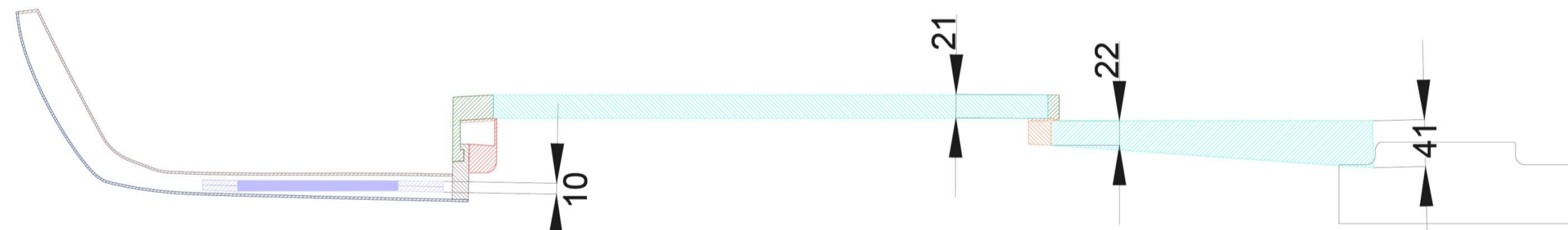

3. PARTICOLARE BINARIO DI  
SCORRIMENTO SCOCCA DA 50cm

SEZIONE A-A

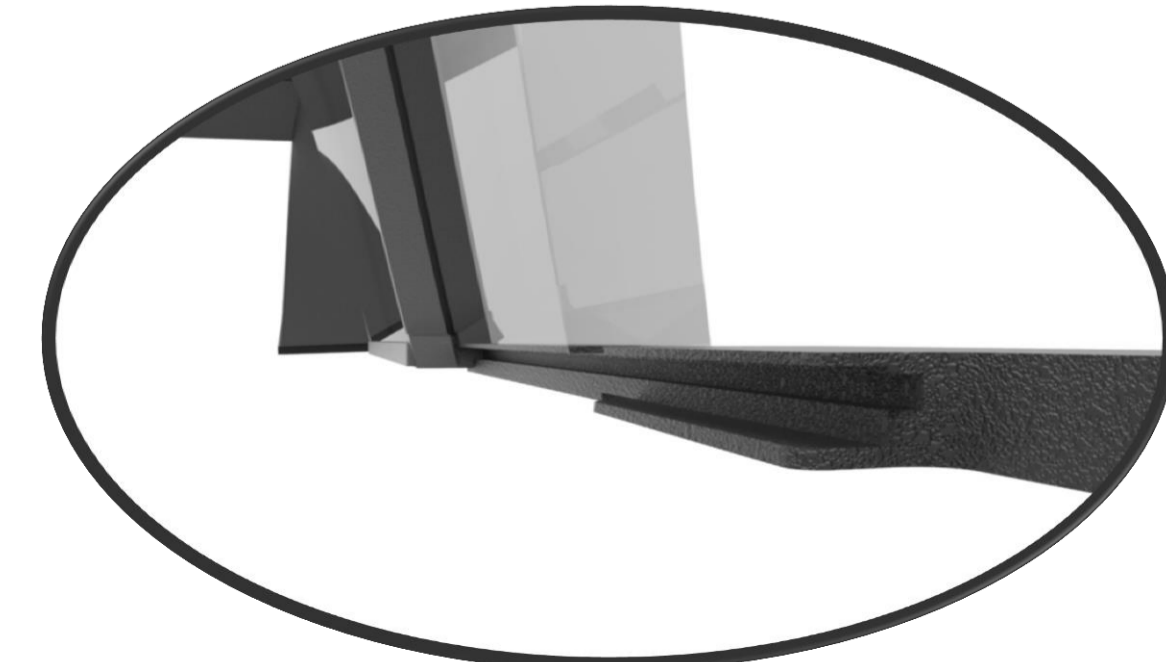

# MUV

## MACROCOMPONENTI: PORTELLONE SDOPPIATO

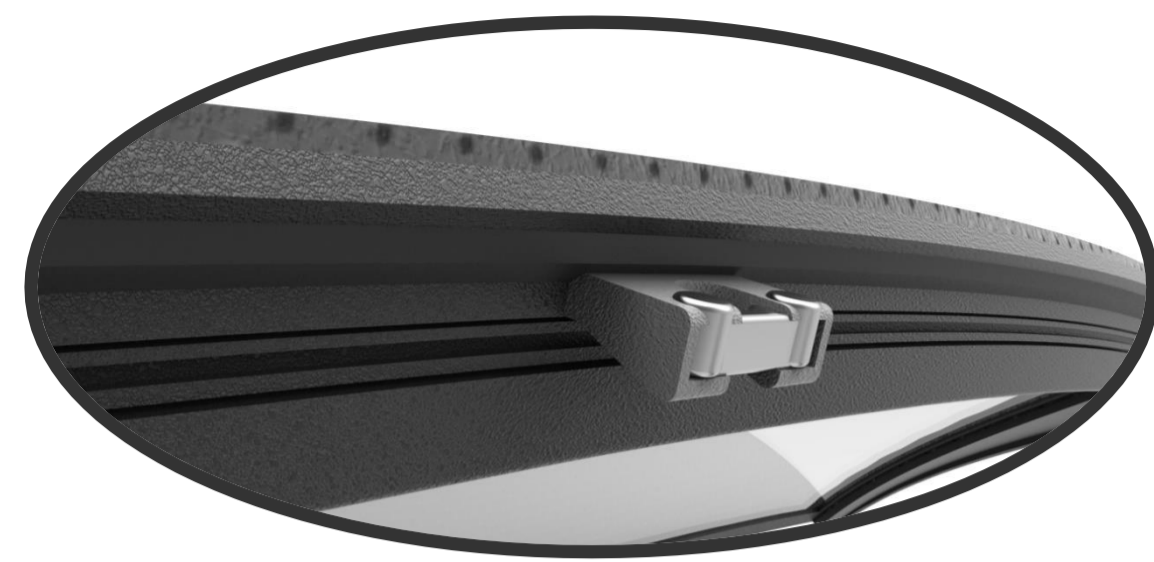

1. ATTACCO CENTRALE PER PORTELLO INFERIORE

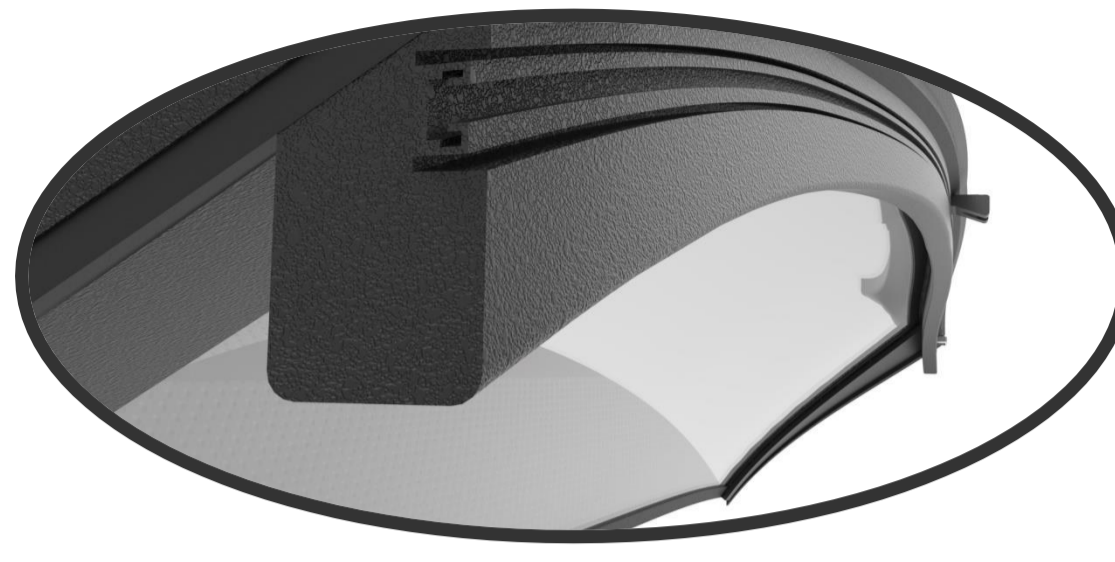

2. BINARIO PER COPERTURA PICKUP

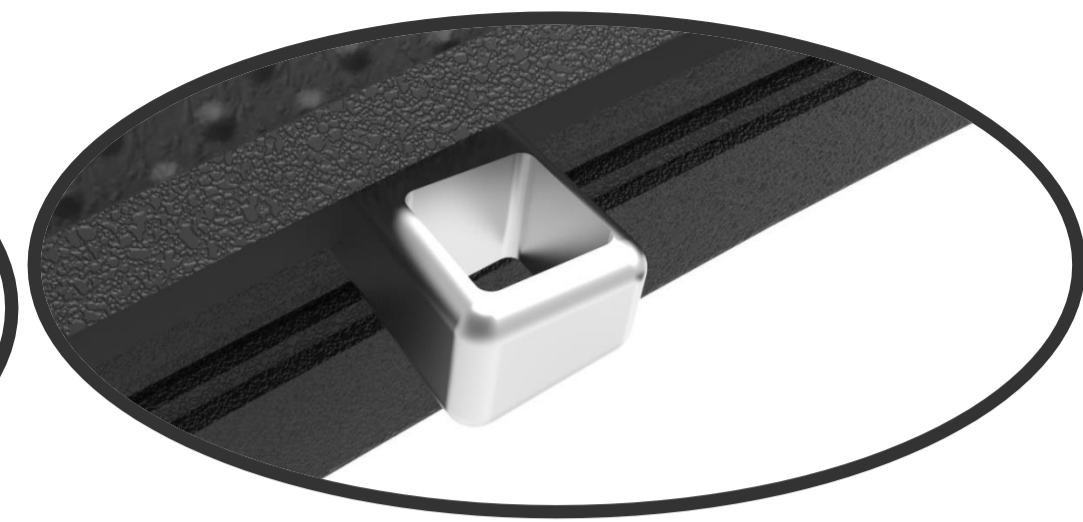

3. ATTACCO LATERALE PER PORTELLO INFERIORE

## LUNOTTO

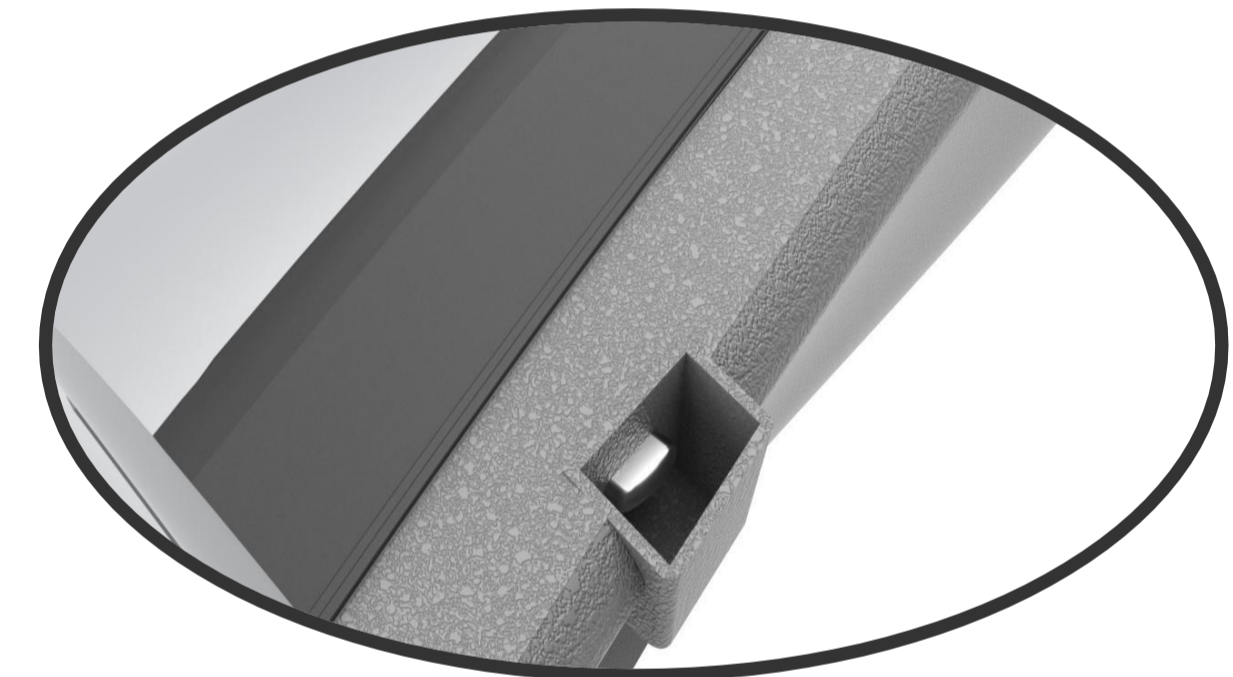
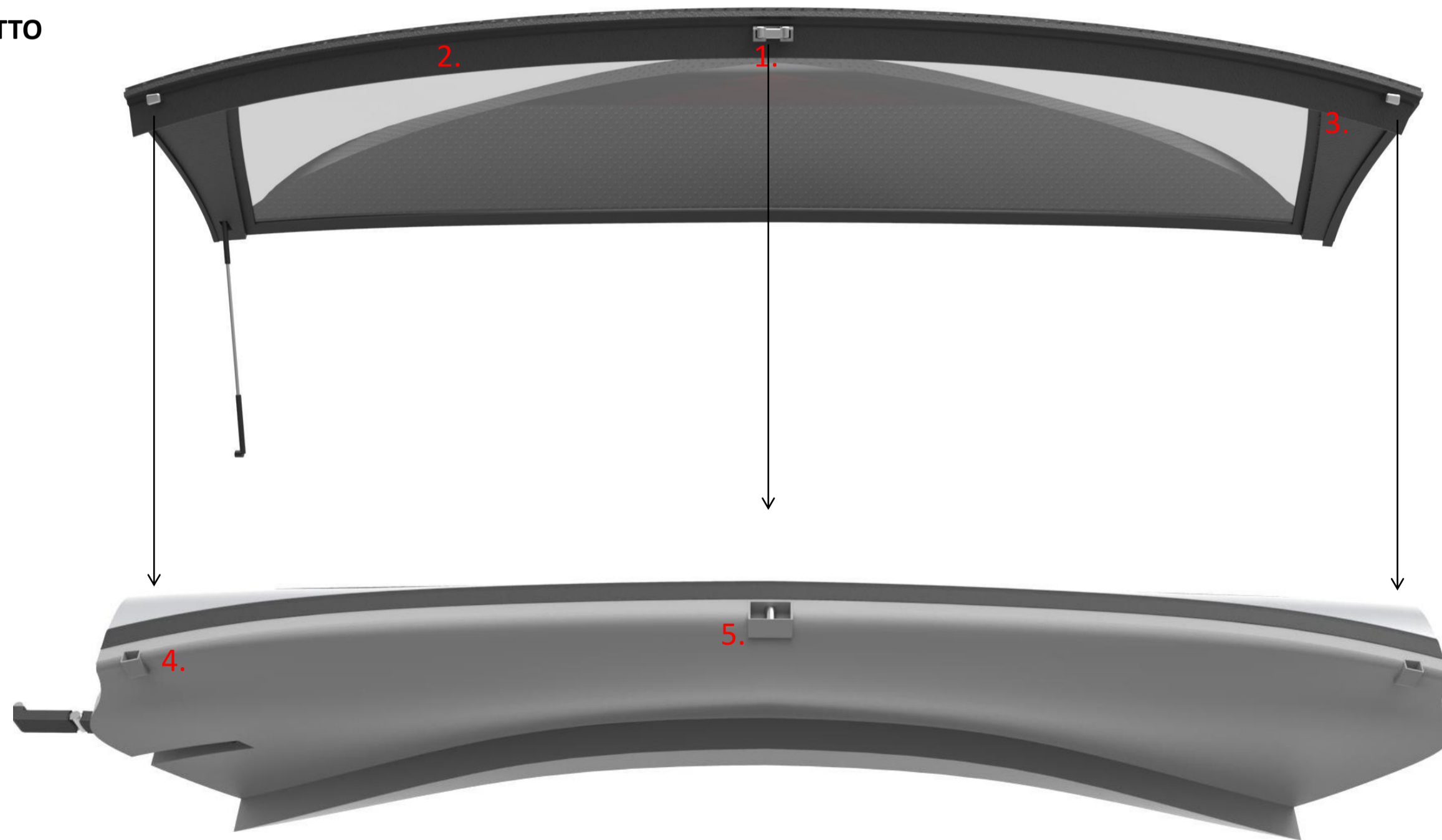

4. ATTACCO LATERALE PER LUNOTTO

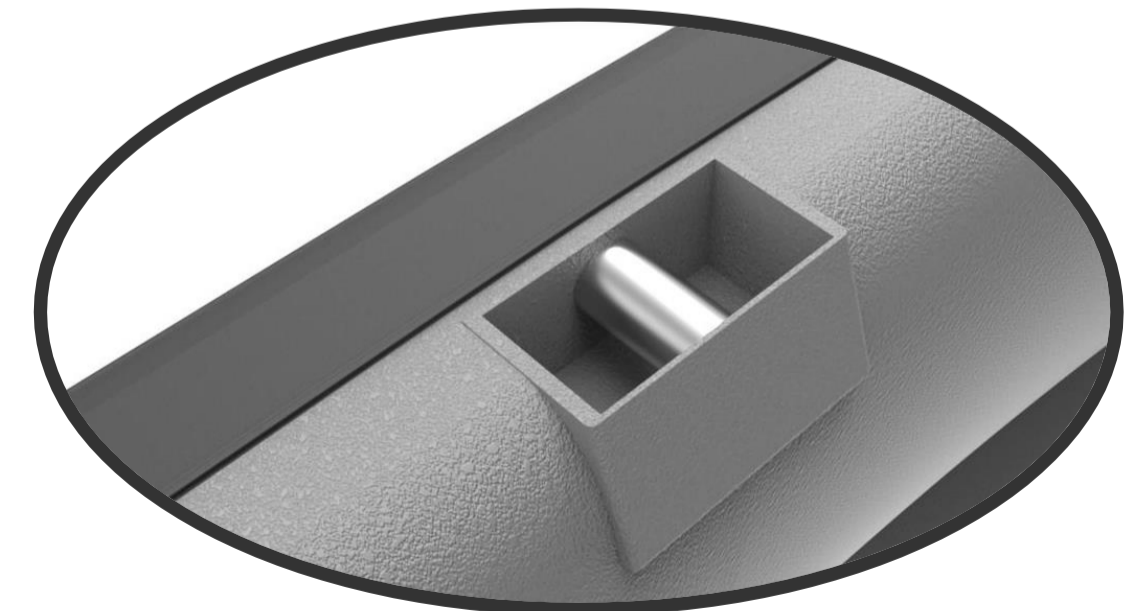

5. ATTACCO CENTRALE PER LUNOTTO

## PORTELLO INFERIORE

# MUV

## MACROCOMPONENTI: MODULO CENTRALE LATERALE

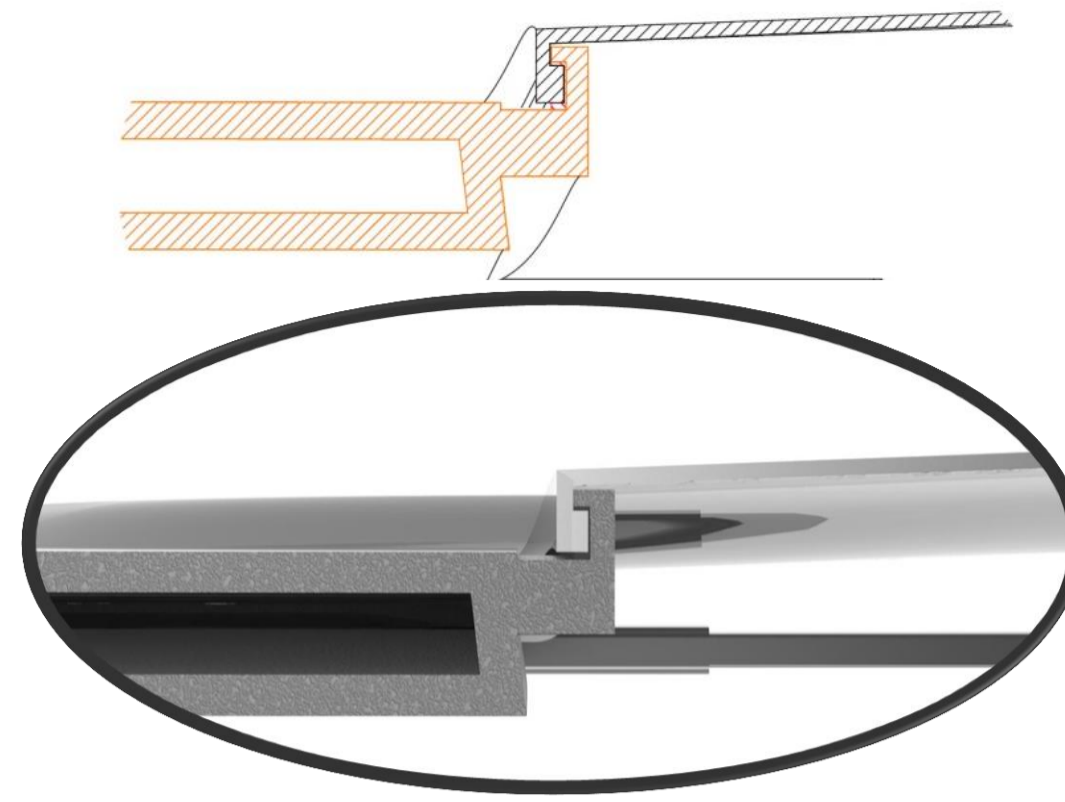
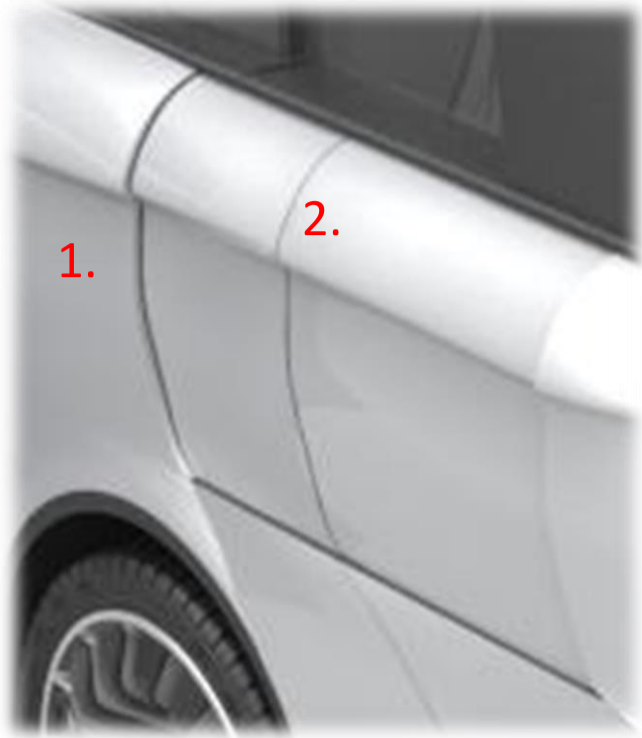

1. INCASTRO SCOCCA FISSA CARROZZERIA CON SCOCCA MOBILE 30cm

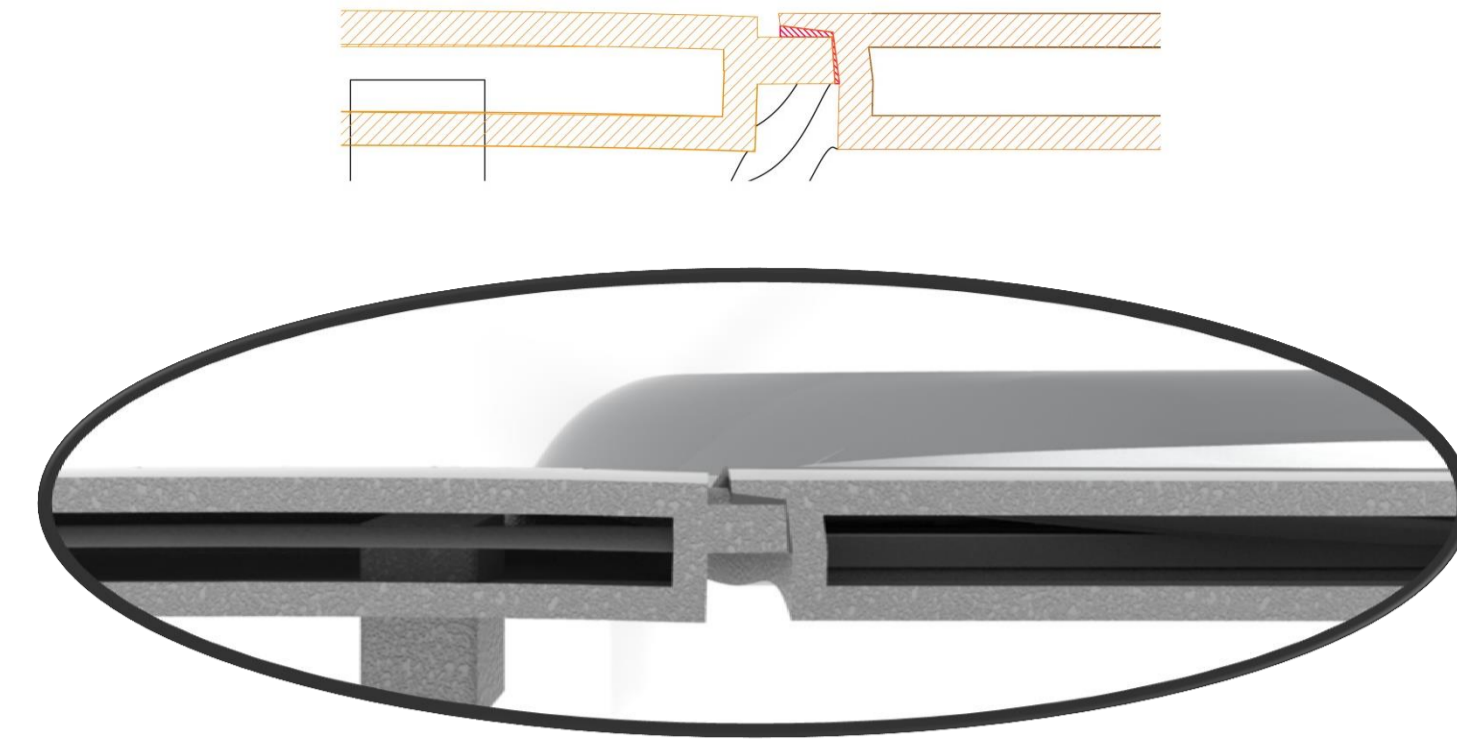

2. INCASTRO SCOCCA MOBILE 30cm CON SCOCCA MOBILE 50cm

POSIZIONE SUL TELAIO

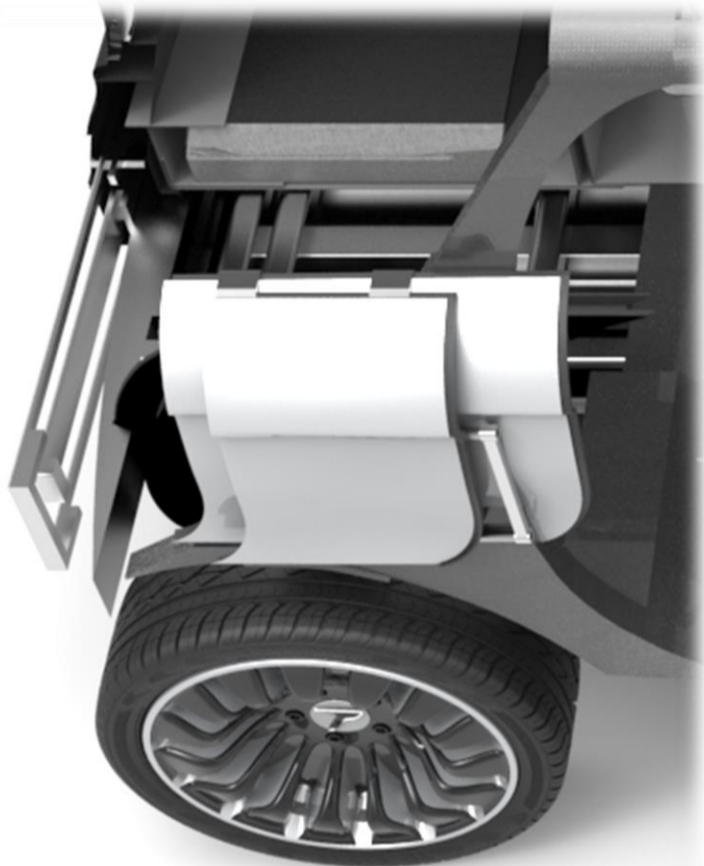

POSIZIONE DI PARTENZA



SPOSTAMENTO SCOCCA DI 30 cm

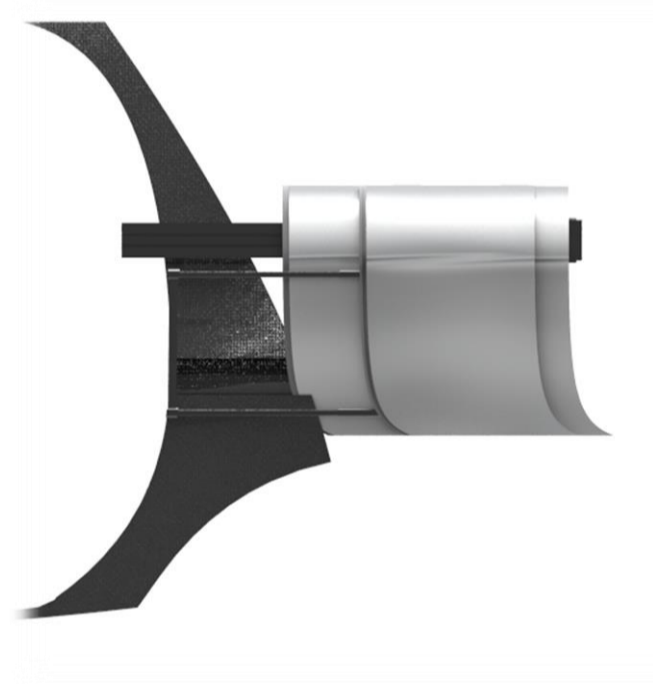

SPOSTAMENTO SCOCCA DI 50 cm

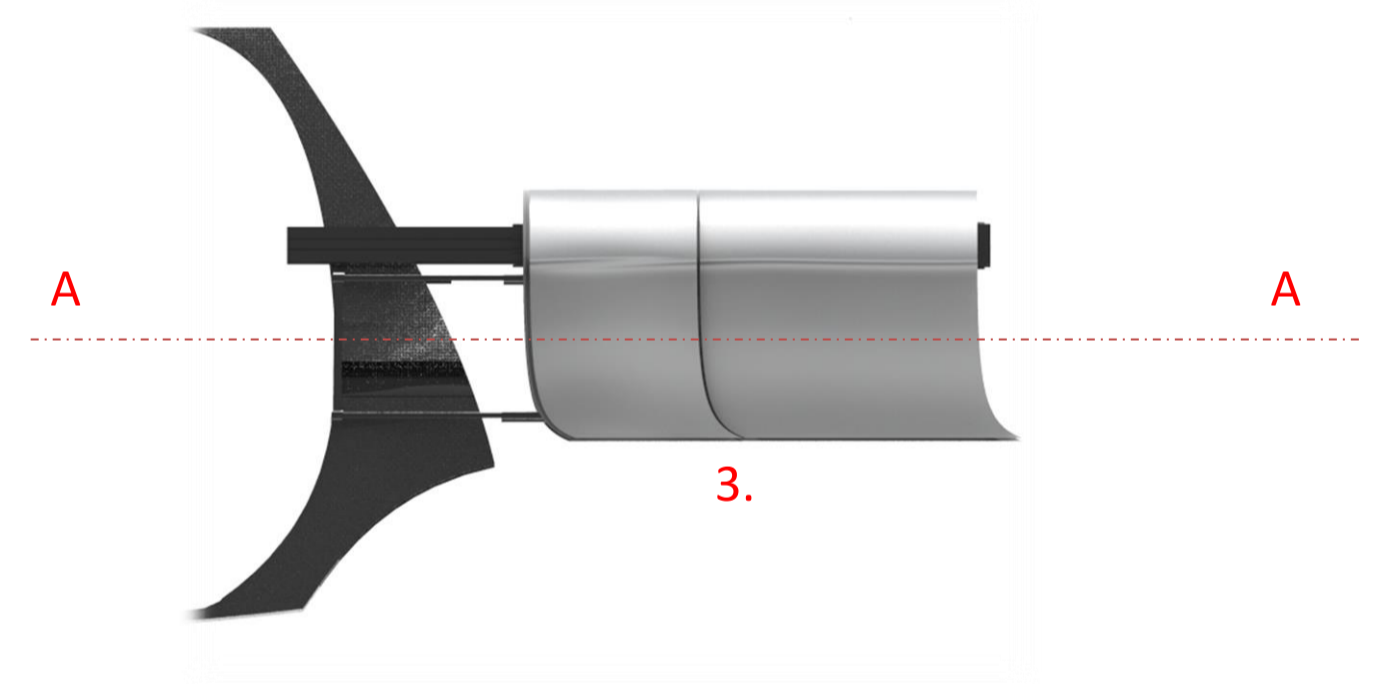

EVOLUZIONE MOVIMENTO MODULO CENTRALE LATERALE

SCOCCA 50cm

SCOCCA 30cm

CARROZZERIA

SEZIONE A-A



TELAIO MOBILE 50cm

TELAIO MOBILE 30cm

TELAIO FISSO

# MUV

## MACROCOMPONENTI: MODULO INFERIORE LATERALE

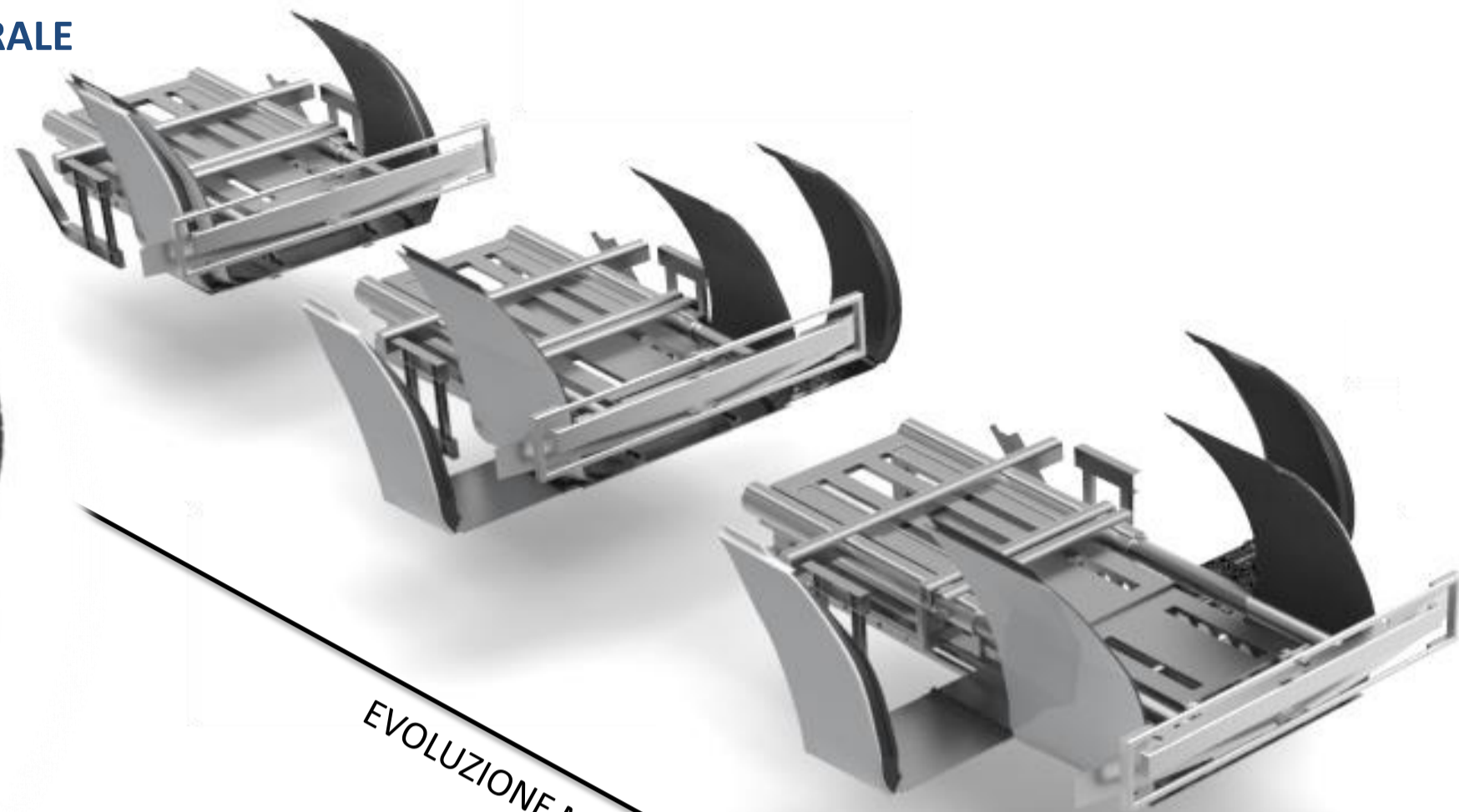

EVOLUZIONE MOVIMENTO MODULO INFERIORE LATERALE

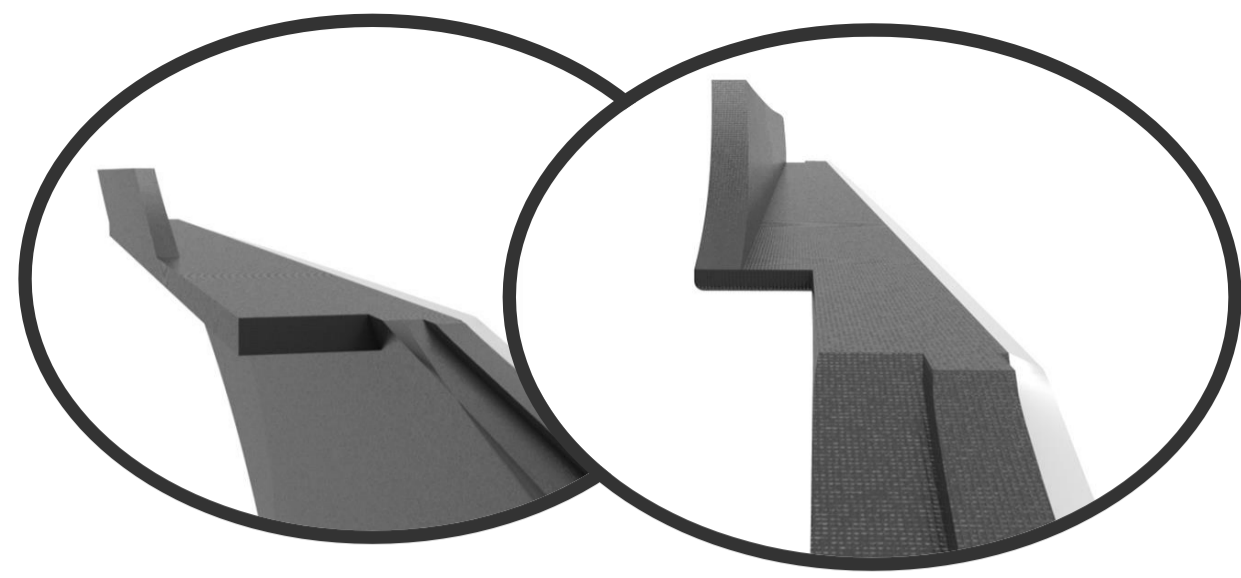

1.-2. PARTICOLARE PROFILO INCASTRI SCOCHE LATERALI

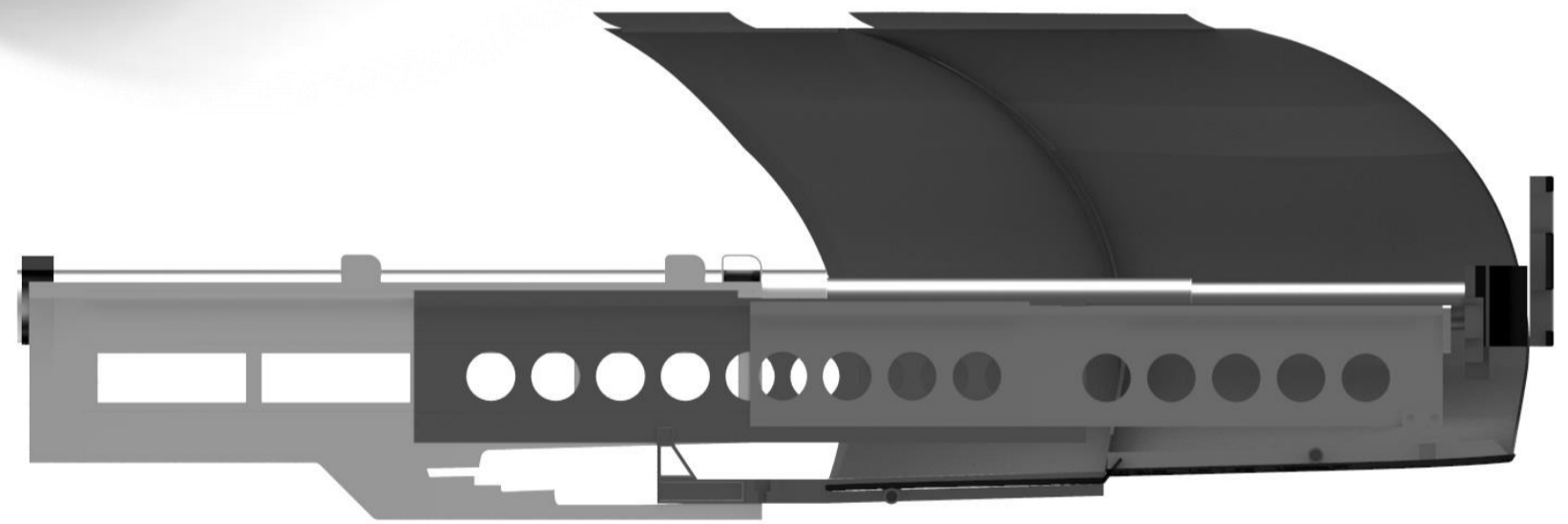

SEZIONE A - A

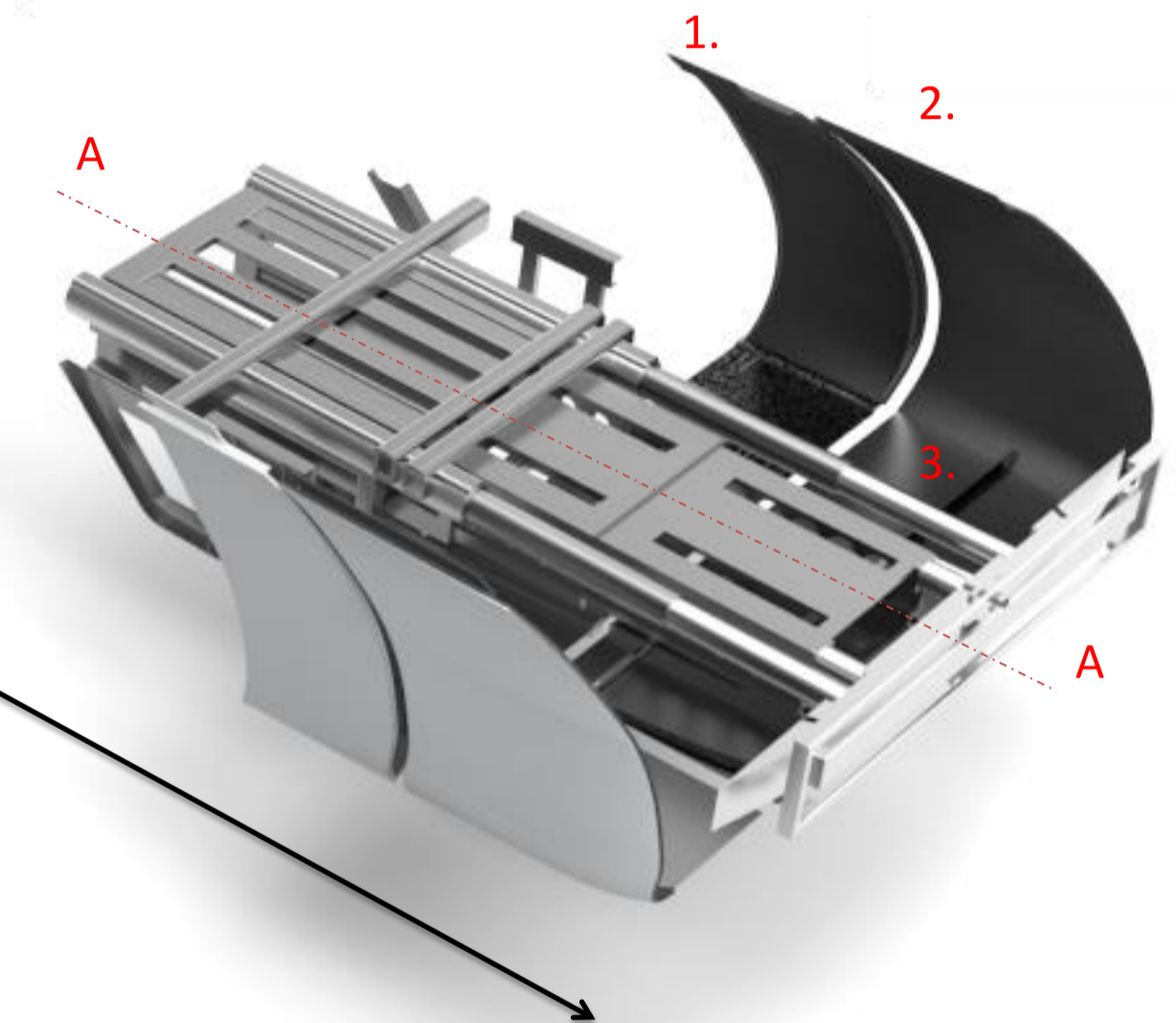

SEZIONE B - B

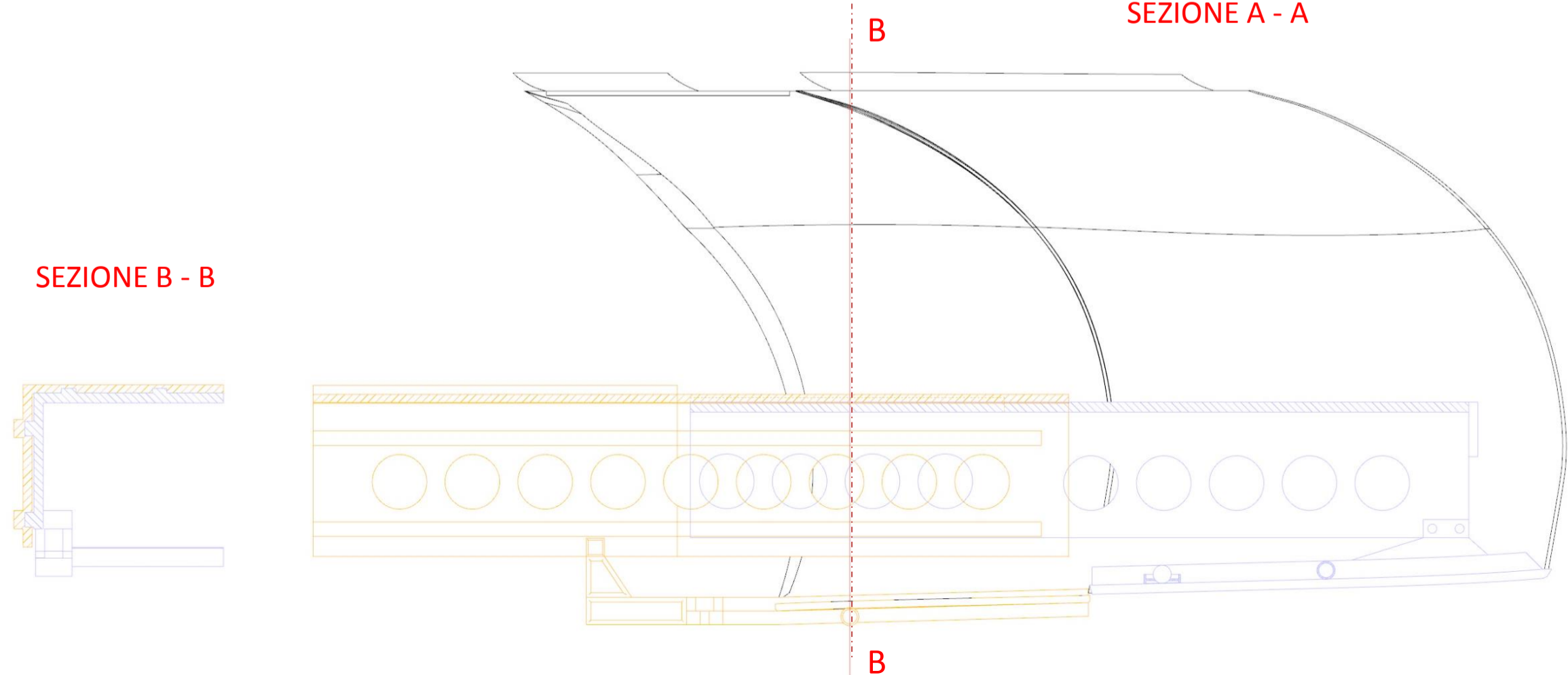

3. PISTONCINO CHE CONSENTE IL MOVIMENTO LATERALE DELLA SCOCCA DA 50 cm

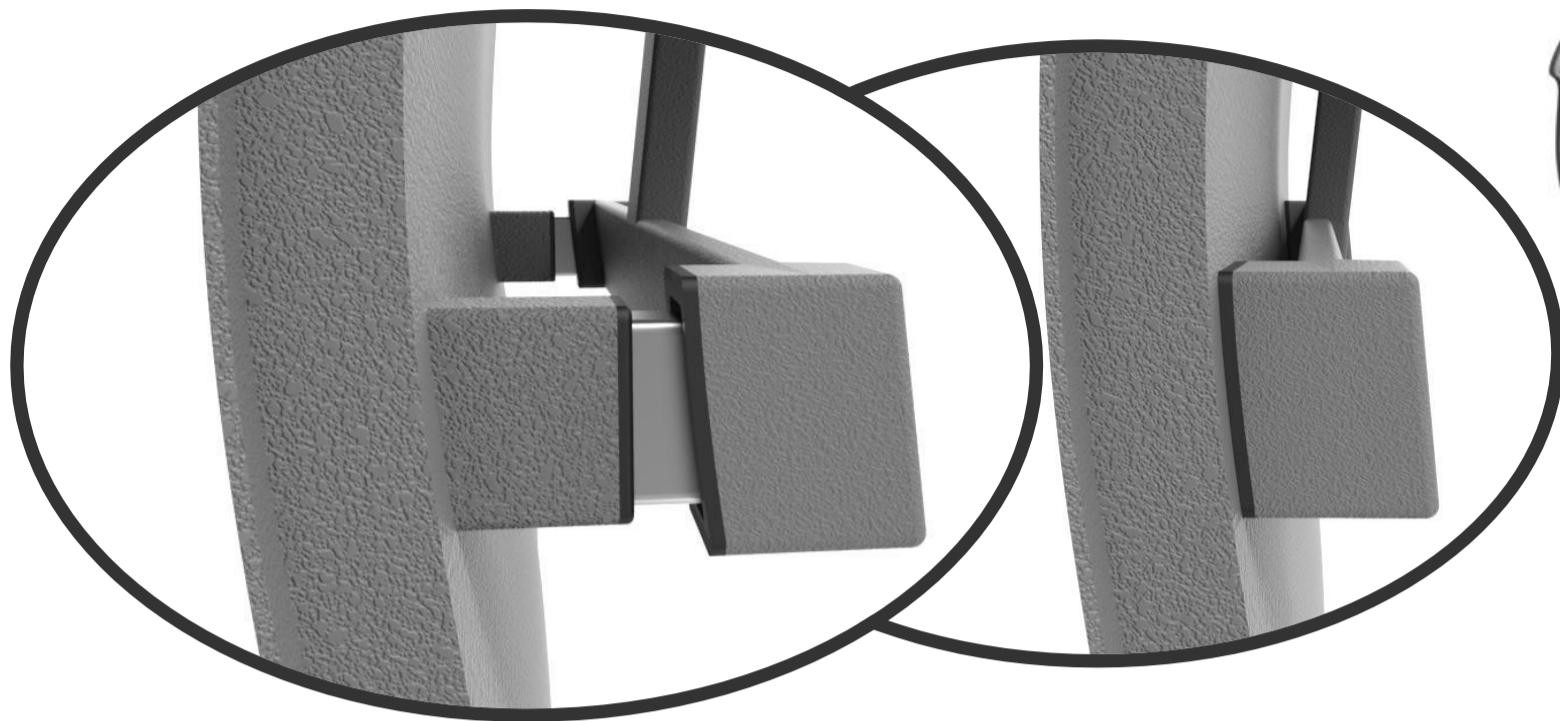

5. SPOSTAMENTO SCOCCA SUPERIORE 50cm

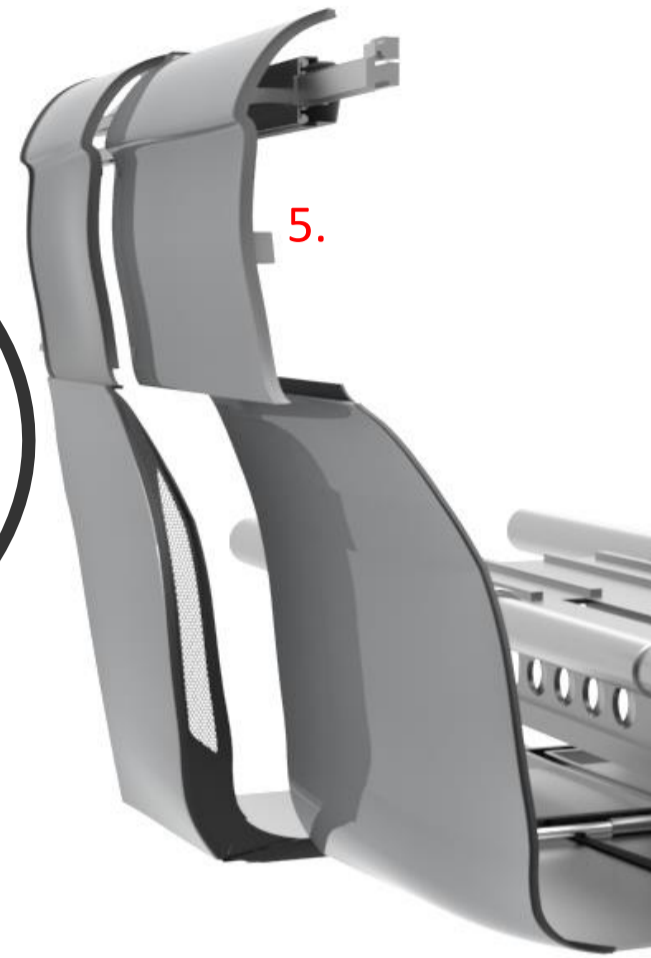

SPOSTAMENTO LATERALE



CONTATTO FRA LE DUE SCOCCHE



ALLINEAMENTO SCOCCHE

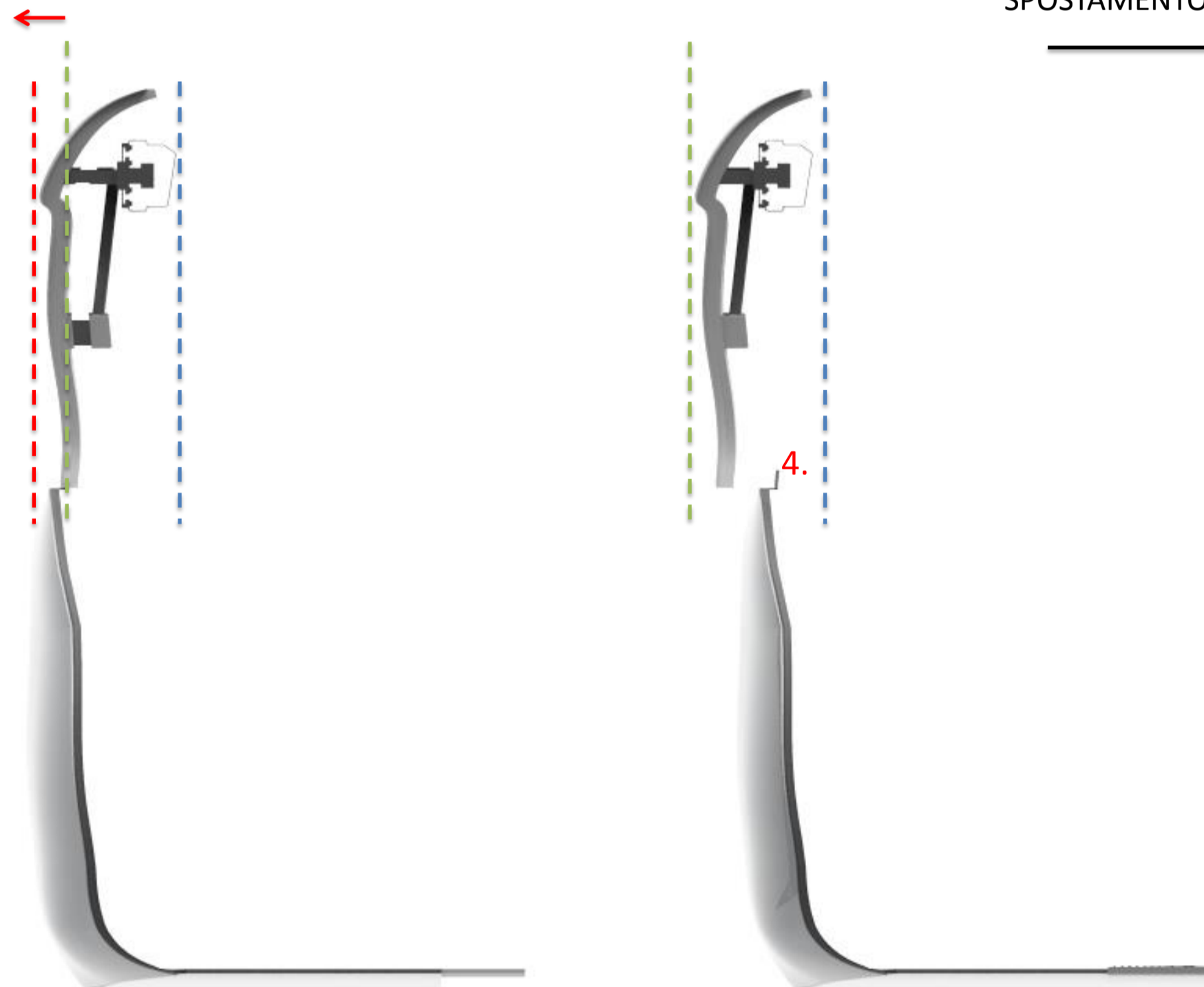

MOVIMENTO MODULO INFERIORE LATERALE PER ALLINEAMENTO ED INCASTRO CON MODULO CENTRALE LATERALE



4. INCASTRO SCOCCA MOBILE **MODULO CENTRALE LATERALE** 50cm CON SCOCCA MOBILE **MODULO INFERIORE LATERALE** 50cm

# MUV

## MACROCOMPONENTI: MODULO POSTERIORE AUTOMATIZZATO

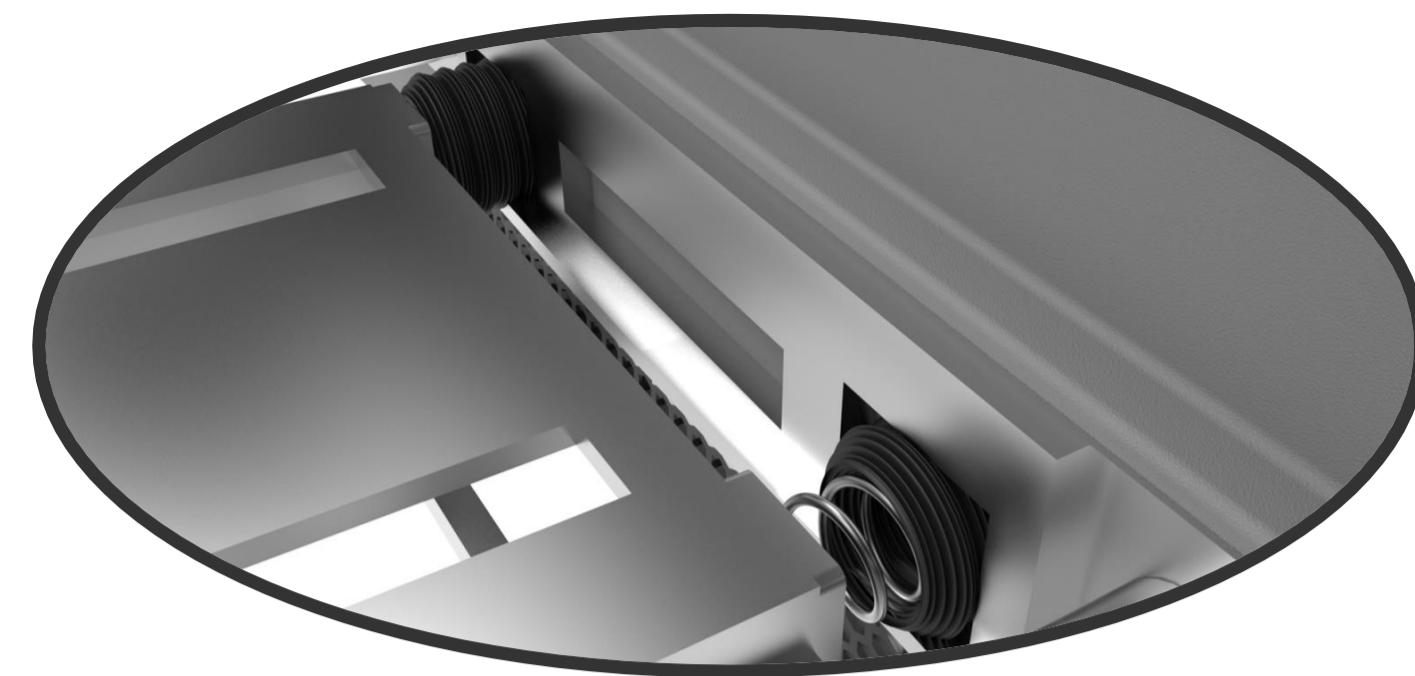
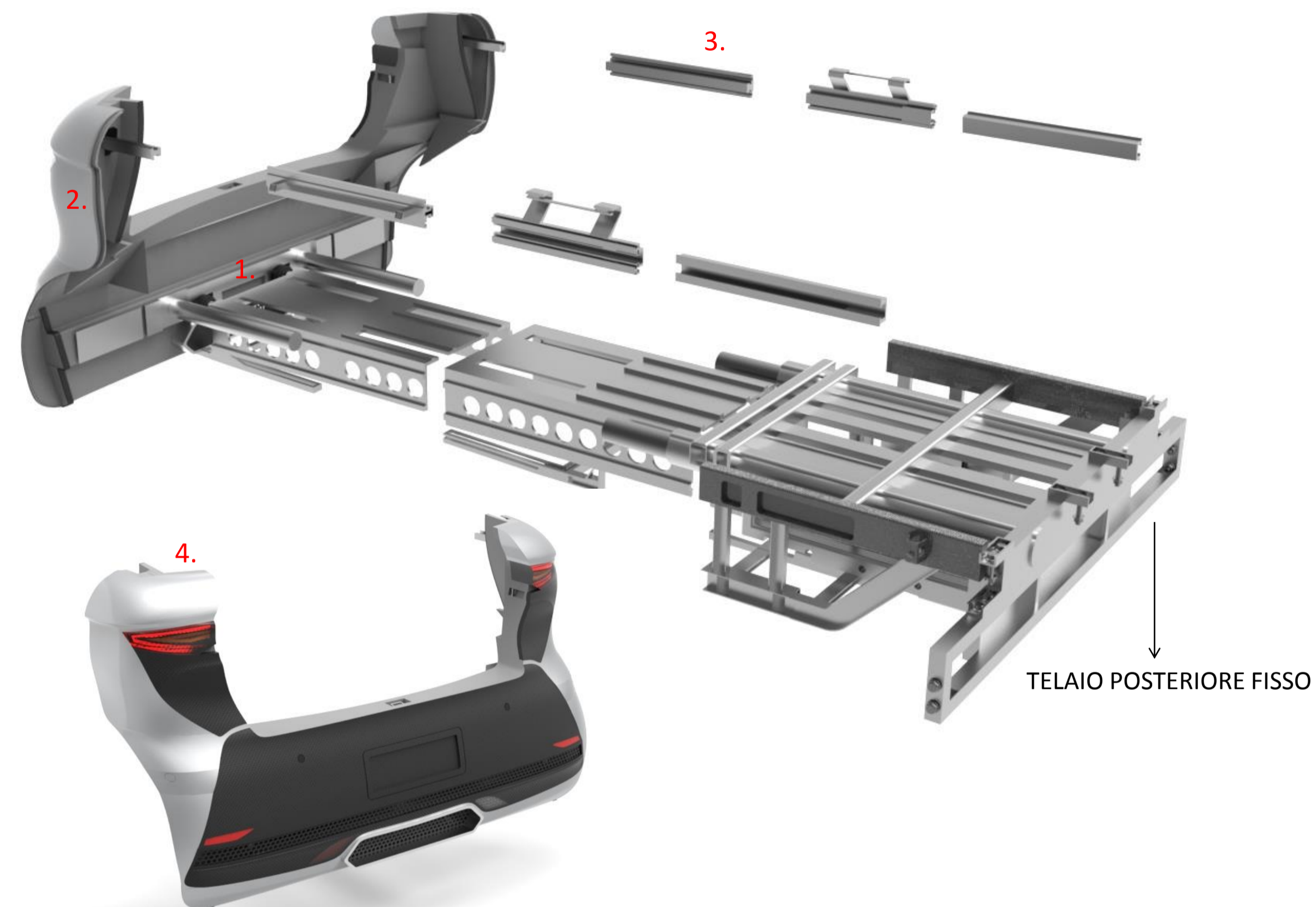

1. MOLLA DI ASSISTENZA AL MOVIMENTO



2. PROFILI PLASTICHE MODULO POSTERIORE

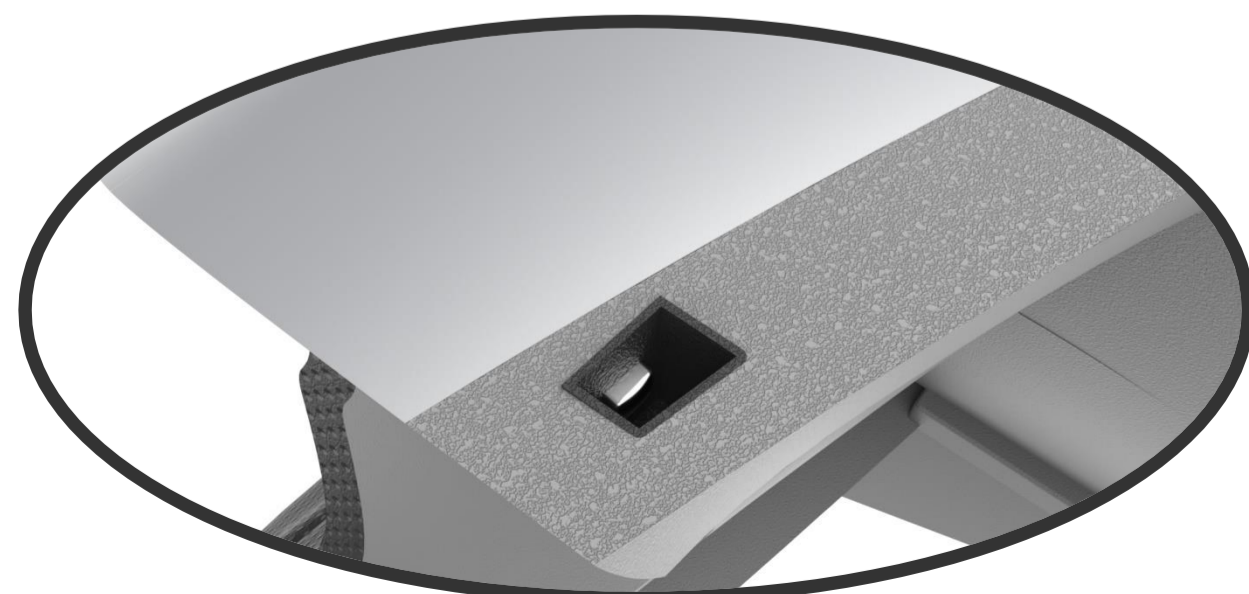

4. ATTACCO PER MODULO SUPERIORE

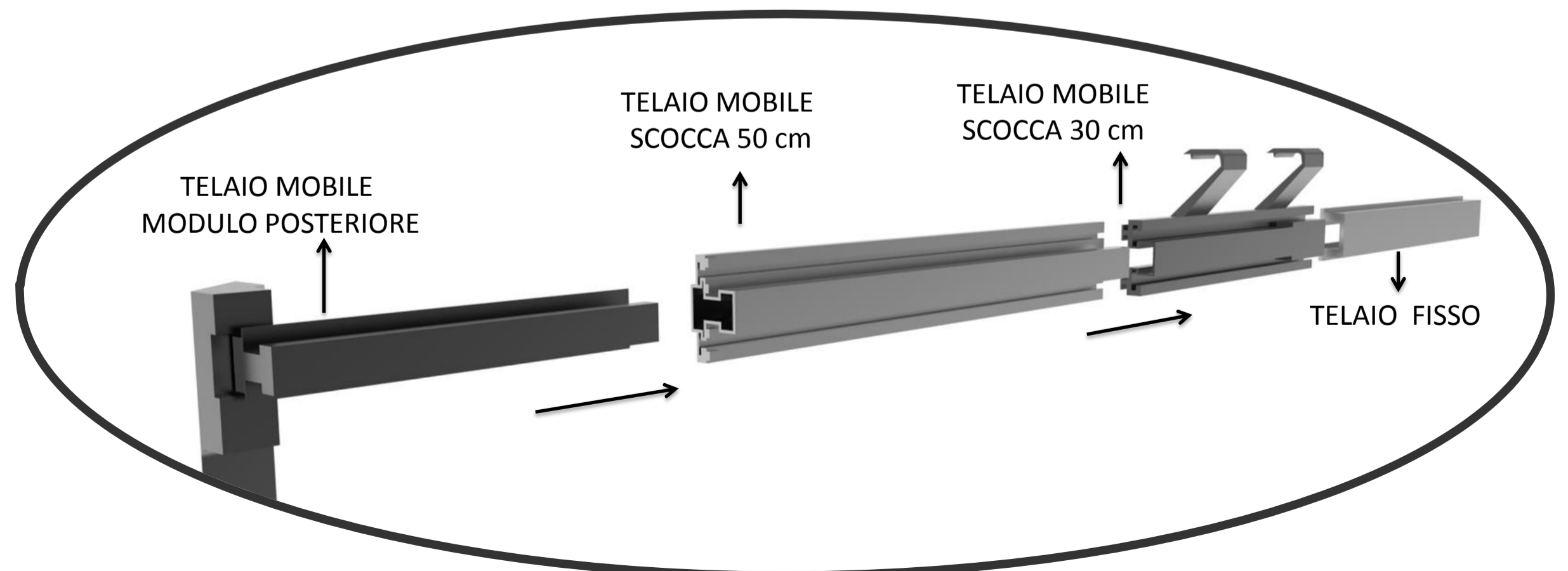

3. ESPLOSO TELAIO LATERALE AD INCASTRO

# MUV

## COME FUNZIONA?

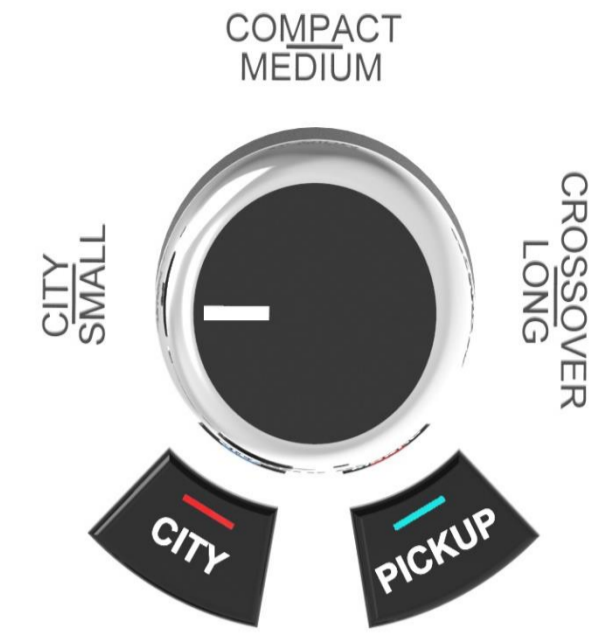
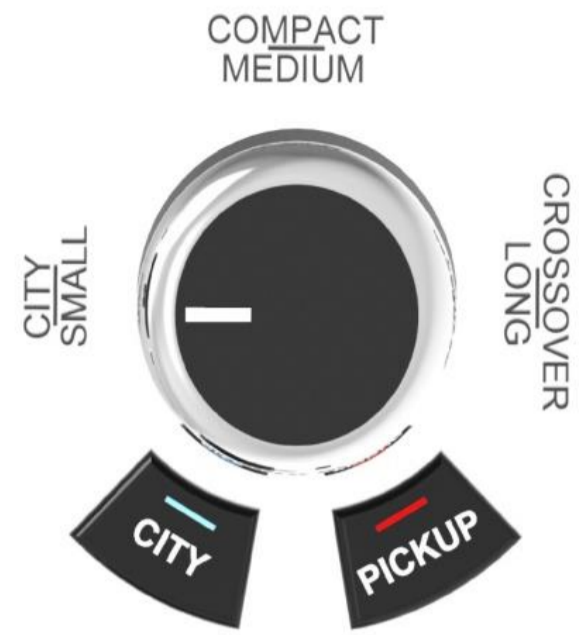

## MODE SELECT : CITY

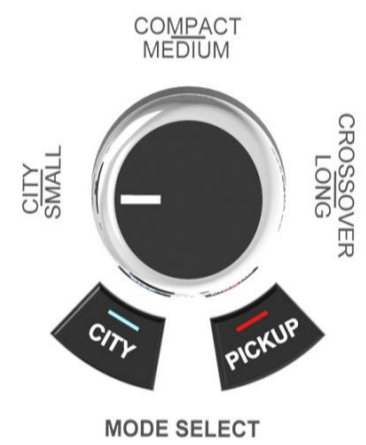

SMALL

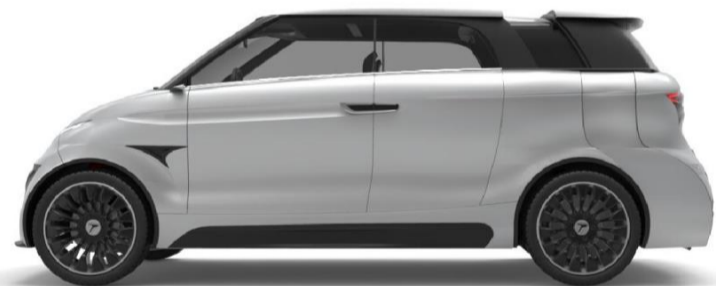
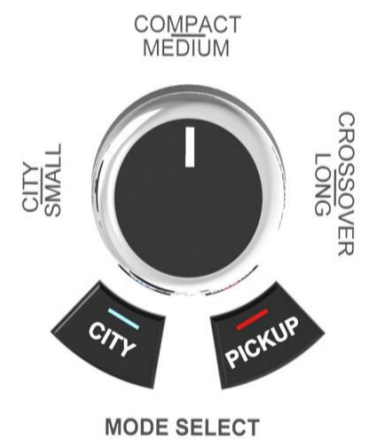

MEDIUM

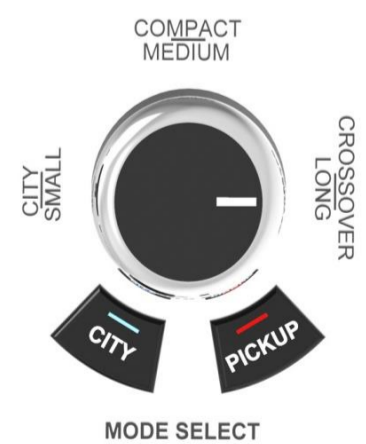
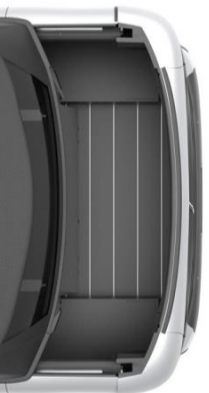

LONG



## MODE SELECT : PICK UP

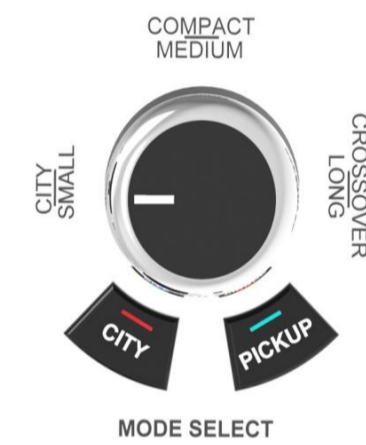

SMALL

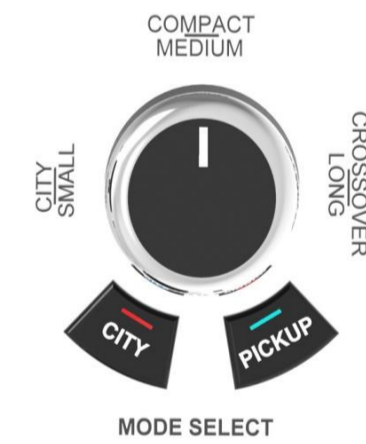

MEDIUM

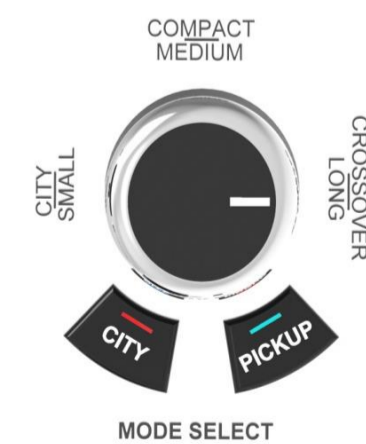
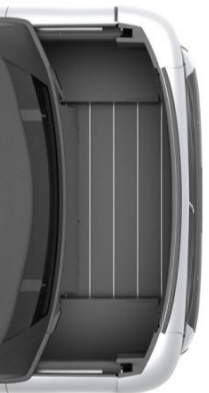

LONG



## FUNZIONAMENTO TELAIO

# MUV MATERIALI

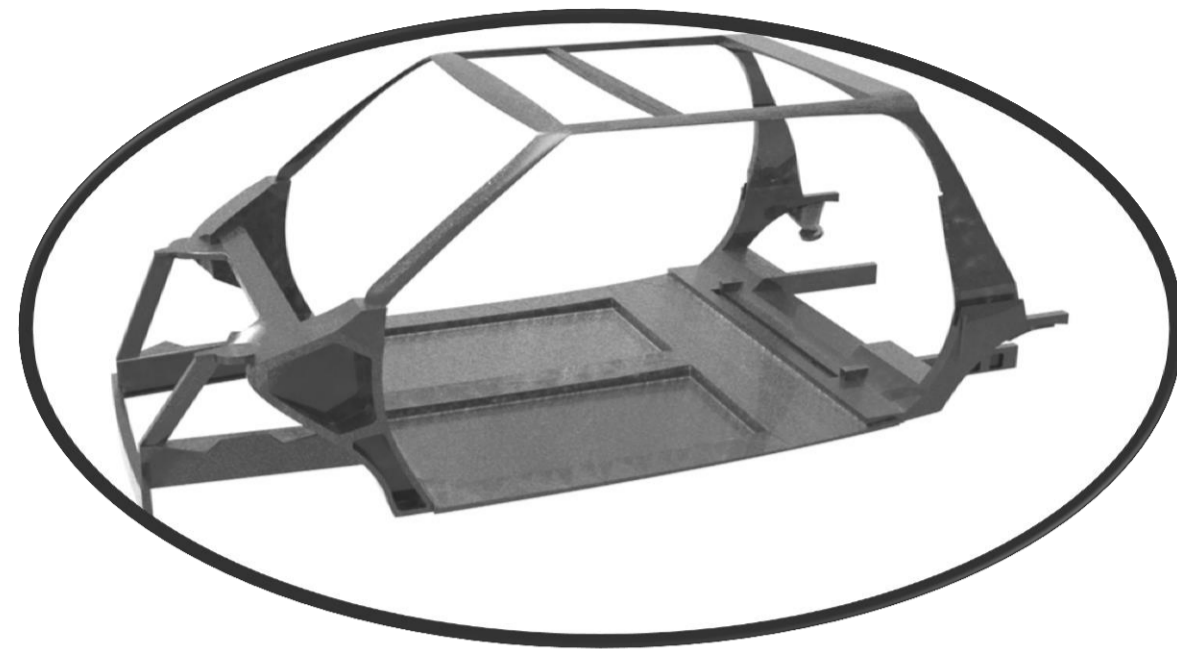

## FIBRA DI CARBONIO

Riciclo

Chimico per Pirolisi che separa le resine dalla fibra di carbonio (riordino delle fibre con il processo di cardatura)



## TESSUTO E PELLE

Riciclata

Impiegata per nuovi oggetti come borse e indumenti di moda (es.azienda Regenesi)



## RAME

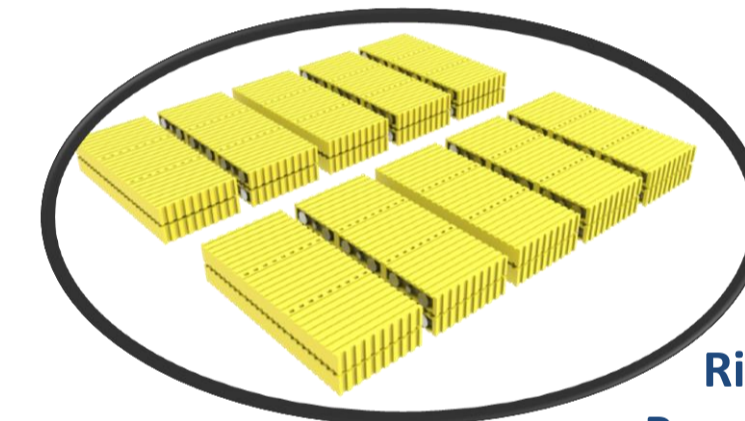

## BATTERIE

Riciclo AZIENDA SNAM  
Processo di Pirolisi avanzato per batterie (elementi costruttivi separati) per estrarre cobalto e nichel .  
Riciclo fino al 60%

## ALLUMINIO

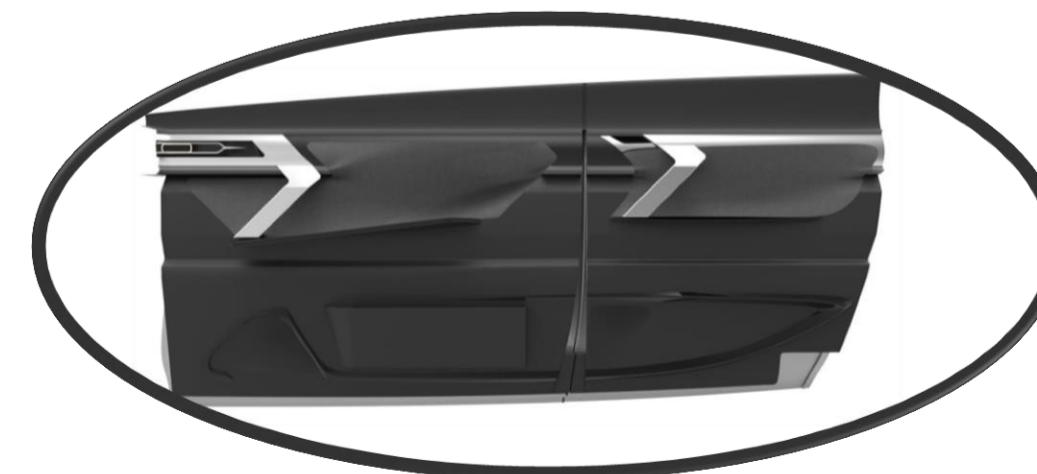
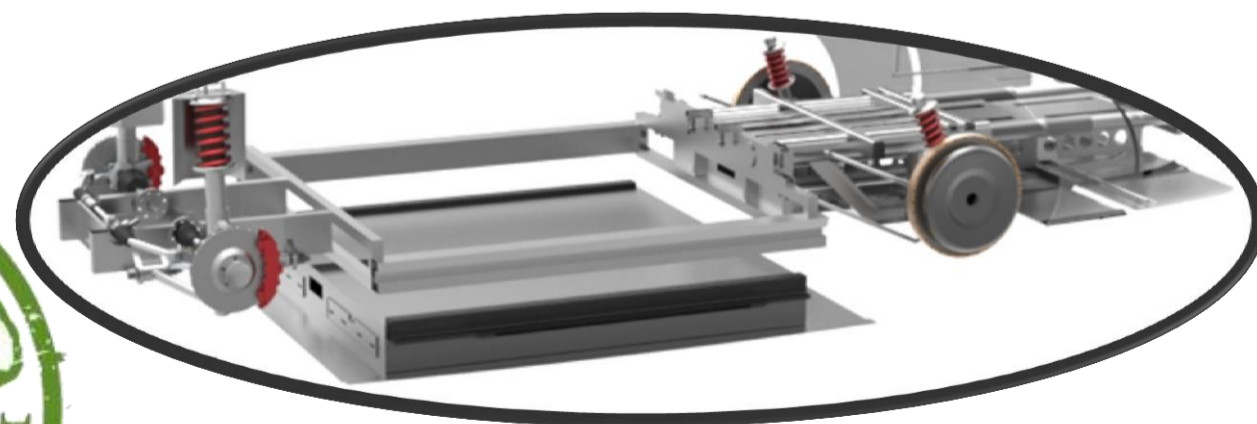

## PLASTICA

Riciclo  
Meccanico (scagli e granuli) o Chimico per idrolisi



**MUV E-POWER**  
IL FUTURO DELLA MOBILITÀ MODULARE ELETTRICA



**GRAZIE PER L'ATTENZIONE**